

FORMAX®

HERE BEGINS YOUR ULTIMATE VALUE

S+M Series
Three-phase Single
Hopper Loader

S6 + M2



Please read the brochure carefully before operation.

■ Coding Principle

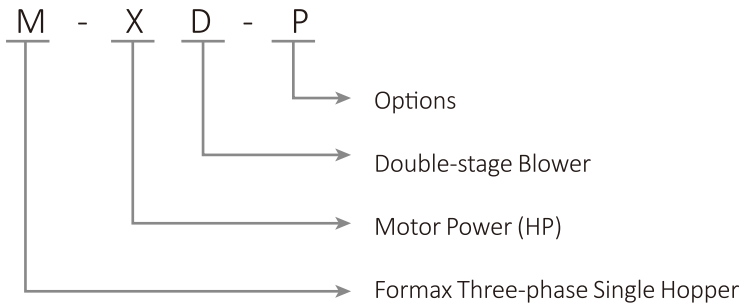

M1+SV3

■ Features

- Two-stage cyclone and filter technology with large dust bin for maintaining quickly and easily.
- Controller build-in proportional valve FPV control function.
- M10 and models above are equipped with broken vacuum valves to protect fans.
- M10 and models above are equipped with pressure storage tanks as standard.
- All series are equipped with stainless steel hopper receivers.
- All series are equipped with filter devices and automatic spray filter devices.

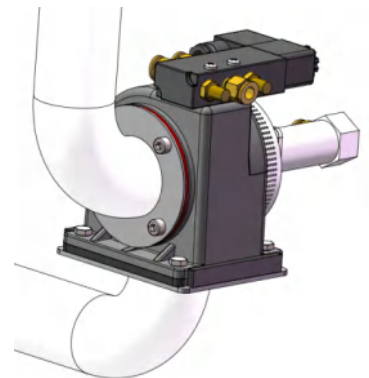

Vacuum breaking valve

■ Conveying Capacity

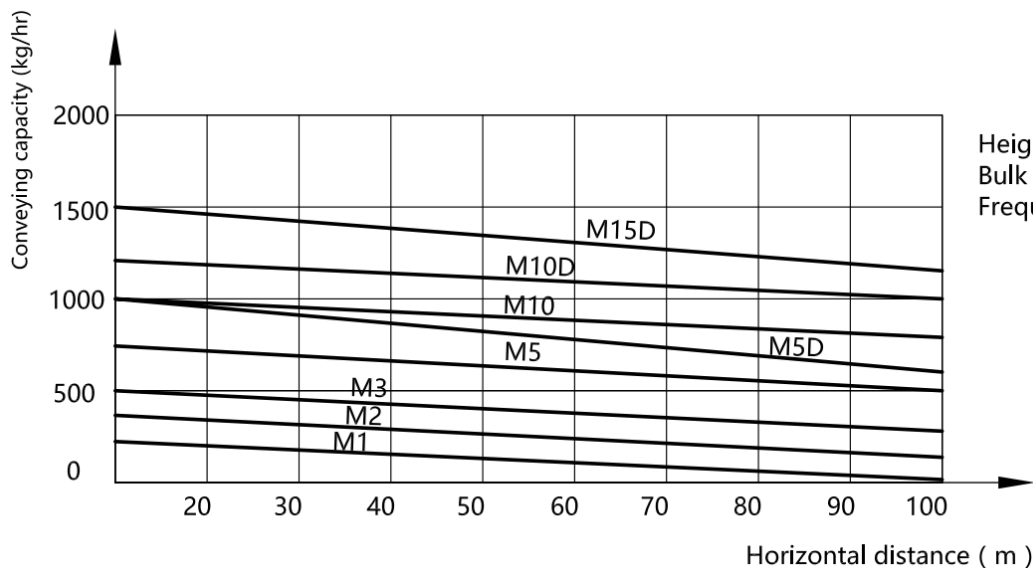

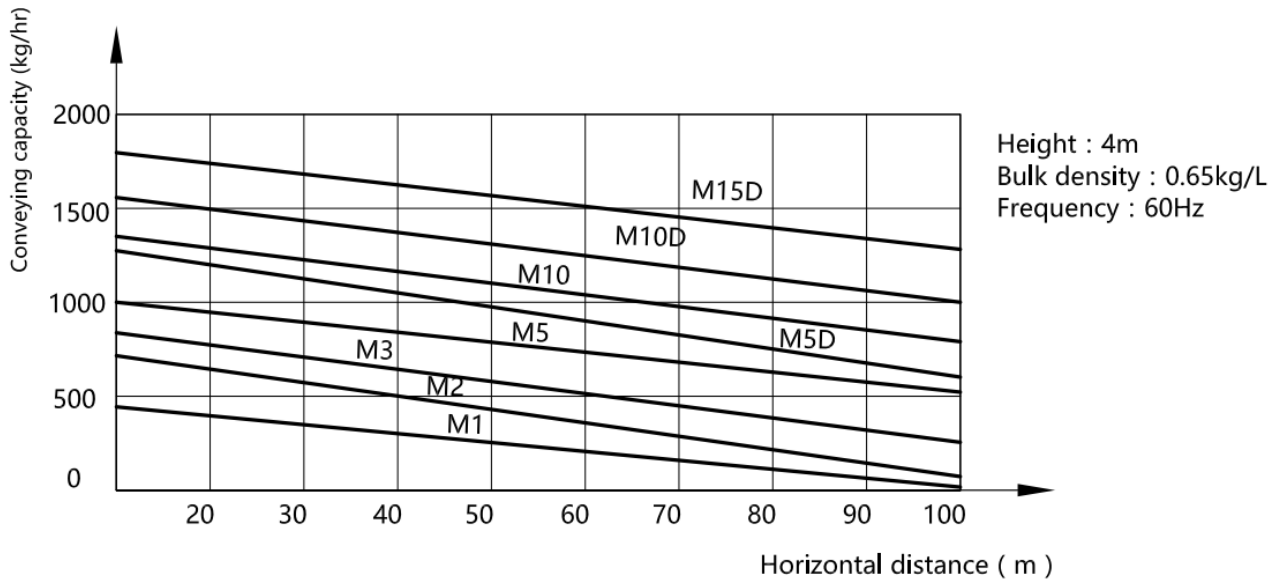

■ Outline Drawings

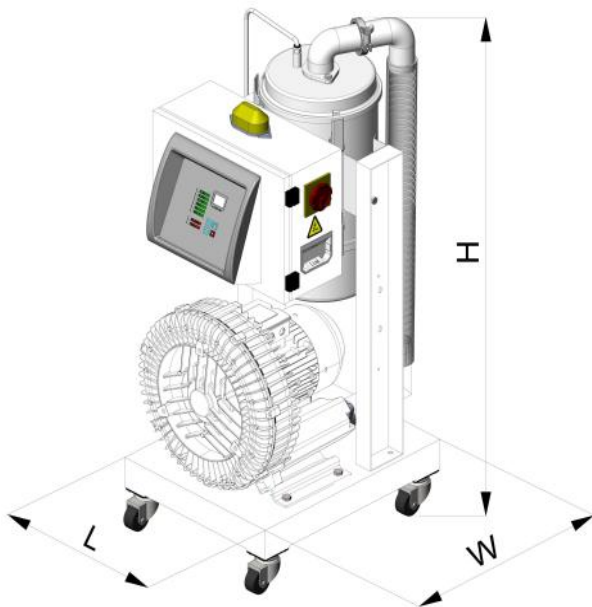

M1~M5 (Main Unit)

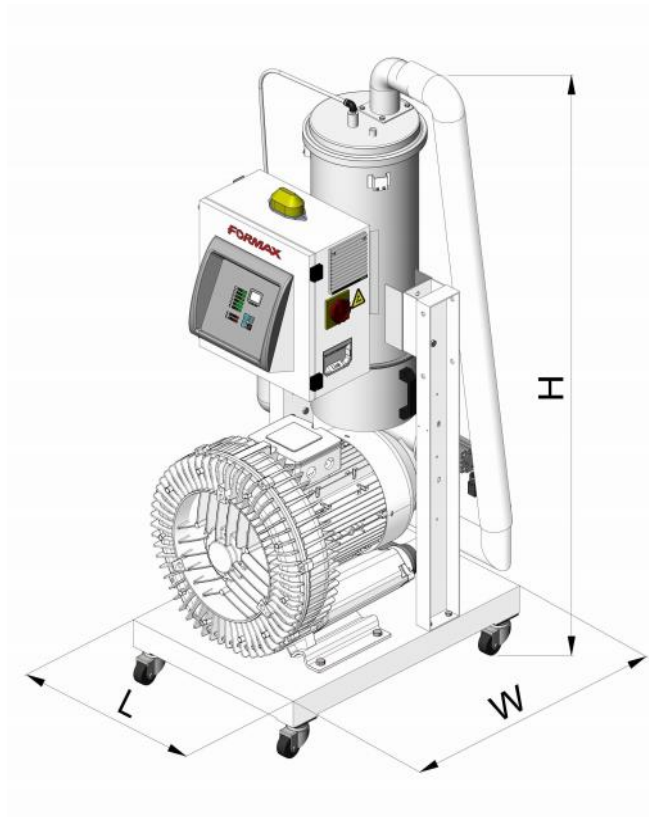

M10~M15D (Main Unit)

■ Specifications

Model	M	M1	M2	M3	M5	M5D	M10	M10D	M15D
Motor Power	kW	0.75	1.5	2.2	4	4	7.5	7.5	1.1
Material Pipe	inch	1.5/2	1.5/2	1.5/2/2.5	1.5/2/2.5	1.5/2/2.5	2/2.5/3	2/2.5/3	2/2.5/3
Vacuum Pipe	inch	1.5/2	1.5/2	1.5/2/2.5	1.5/2/2.5	1.5/2/2.5	2/2.5/3	2/2.5/3	2/2.5/3
Motor Type		Single	Single	Single	Single	Double	Single	Double	Double
	Kg/hr	250/450	400/700	500/800	750/1000	1000/1300	1000/1300	1200/1550	1200/1800
Hopper Capacity	Ltr	3/6	6/12	6/12/24	12/24/36	12/24/36	24/36/48	24/36/48	24/36/48
Voltage	V	3Ø,380VAC,50Hz							
Accessory	Filter dust collector	F6				F12			
	Vacuum valve breaking	N/A				Standard			

Dimension

L	MM	440		485		685		680	
W		545		580		745		950	
H		1000		1000		1400		1600	
Net Weight	Kg	28	38	40	56	56	85	102	126

- Notes: 1) Test condition of conveying capacity : Plastic material of bulk density 0.65kg/L, diameter of 3~5mm, vertical height of 4m and the horizontal conveying Distance of 5m.
2) Power supply : 3Ø, 380VAC, 50/60Hz.

Product specifications are subject to change without prior notice.

FORMAX®

China
Formax Plastics Automation, Inc.

Dongguan
No. 9, Taida Road, Chang'an Town, Dongguan City,
Guangdong Province, China
Tel. +86-769-3899-9898 Fax. +86-769-8533-3467

Kushan
No.138-20, Hengshan Road, Kunshan, Jiangsu, China
Tel. +86-512-5700-8308 Fax. +86-512-5700-8306

Taiwan
Formax Equipment Inc.

No.12, Ln.12, Anzhong st., Luzhu Dist.,
Taoyuan City, Taiwan
Tel. +886-3-2121-725 Fax. +886-3-2127-960

www.formaxpa.com
www.formax88.com



2024-8 All rights reserved.