

**FORMAX**®

HERE BEGINS YOUR ULTIMATE VALUE

**LV** Series  
Venturi Loader

LV-120



Please read the brochure carefully before operation.

## ■ Coding Principle

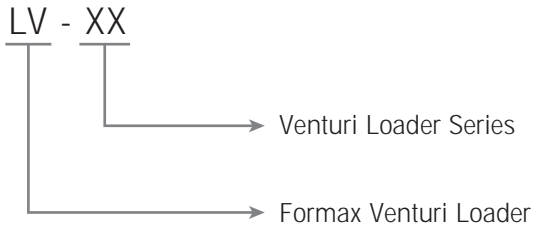

LV-50

## ■ Features

- European-style design, compact structure and light weight.
- Exhaust air and filter to ensure the working environment is not polluted.
- High-pressure air is used to deliver raw materials with extremely low noise.
- Glass tube with static capacitance sensor design for accurate material convey.
- Equipped with a filter pressure regulator to filter the moisture of the air and ensure stable air pressure.
- Easy to install, easy to operate, fully polished.
- When changing raw materials, the hopper is easy to disassemble and easy to clean.



Controller & Venturi

## ■ Application

- ① Material storage tank
- ② Hopper dryer
- ③ Venturi loader
- ④ FVS Screw doser

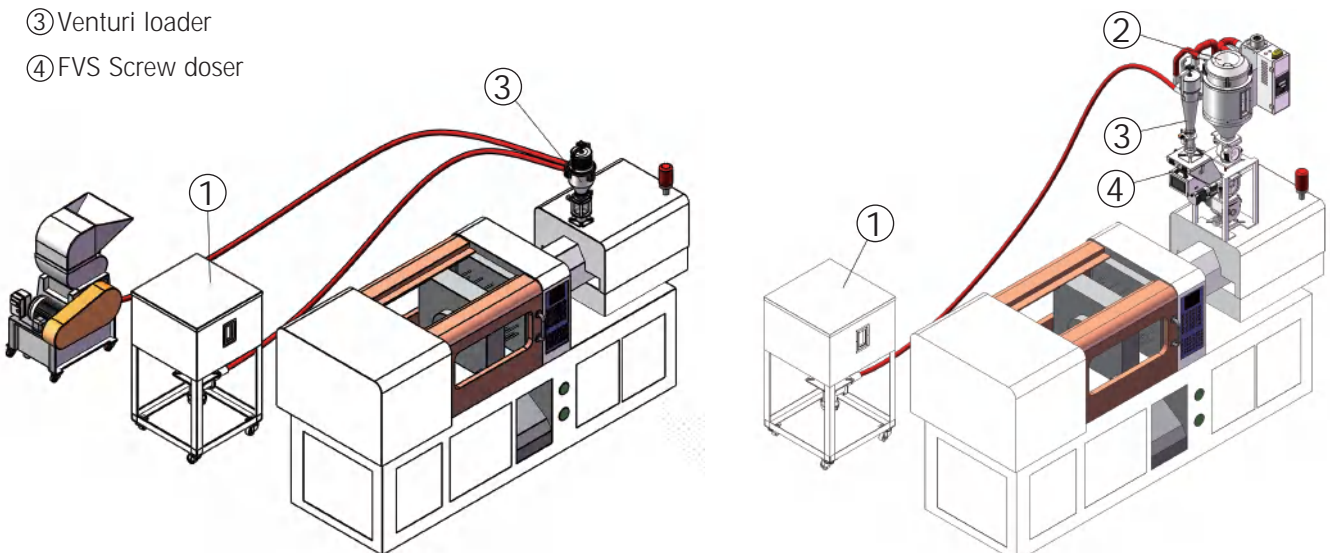

■ System Structure Drawings

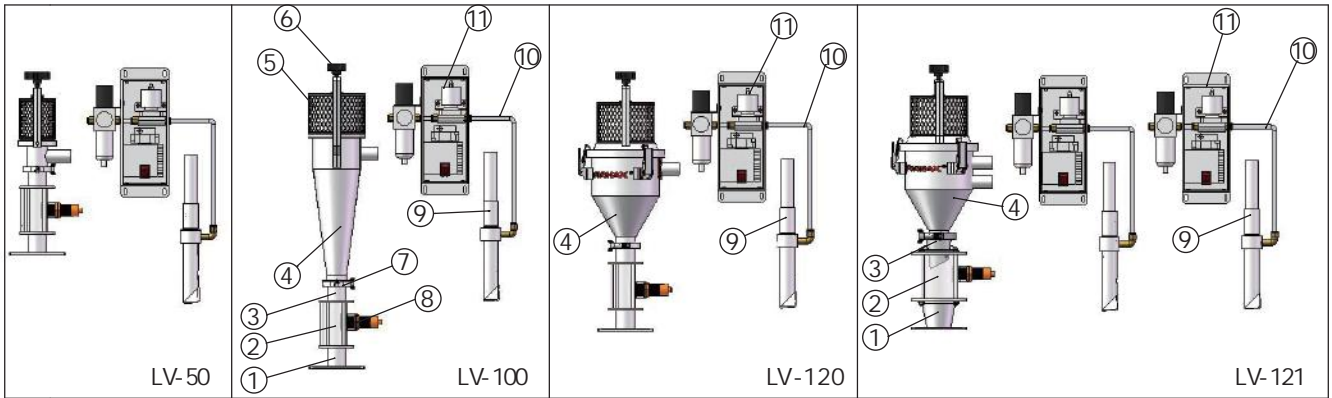

- ① Base bottom ② Glass tube ③ Up base bottom ④ Hopper ⑤ Filter ⑥ Lobe knob
- ⑦ Ferrule ⑧ Level sensor ⑨ Wand ⑩ Air pipe ⑪ Control unit

■ Outline Drawings

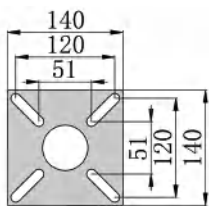
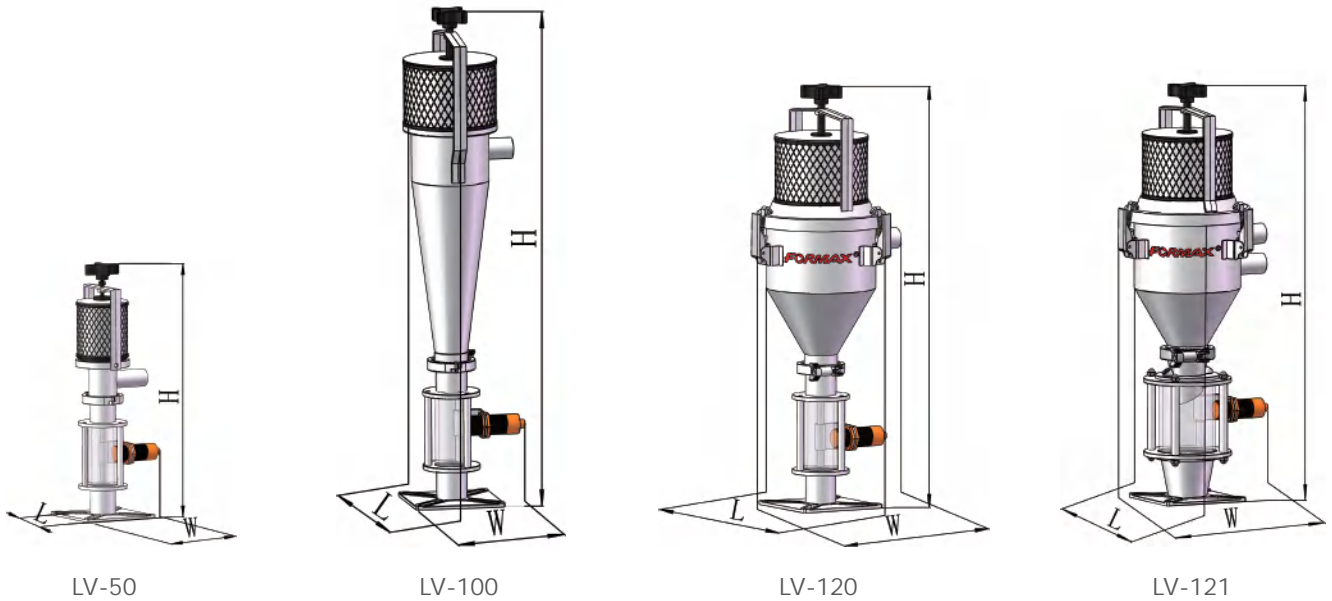

Dimension of Bottom Flange  
LV-50/100/120

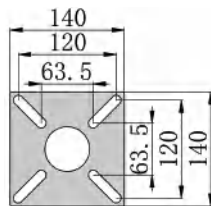

Dimension of Bottom Flange  
LV-121

## ■ Specifications

Model	Throughput ( kg/hr )	Hopper Capacity ( L )	Air Flow ( L/hr )	Compressed Air ( kgf/cm <sup>2</sup> )	Conveying Distance ( m )	Tube Dia. ( inch )	Wand Length ( mm )	Outline Dimensions (mm) ( L*W*H )	Net Weight ( kg )
LV-50	40	0.5	6,000	6.0	6	1.25	900	215x140x485	4.5
LV-100	60	2.8	6,000	6.0	6	1.25	900	186x160x772	7
LV-120	80	3	6,000	6.0	6	1.25	900	197x253x655	7.5
LV-121	80	3	6,000	6.0	6	1.25	900	197x253x668	8.5

Note: 1) Test condition of throughput: plastic material of bulk density 0.8kg/L, dia. 3-5mm, vertical conveying height 2m, horizontal conveying distance 1m.  
2) Voltage : 1Ø , 230VAC, 50Hz

Specifications are subject to change without prior notice.

# FORMAX®

China  
**Formax Plastics Automation, Inc.**

Dongguan  
No. 9, Taida Road, Chang'an Town, Dongguan City,  
Guangdong Province, China  
Tel. +86-769-3899-9898 Fax. +86-769-8533-3467

Kushan  
No.138-20, Hengshan Road, Kunshan, Jiangsu, China  
Tel. +86-512-5700-8308 Fax. +86-512-5700-8306

Taiwan  
**Formax Equipment Inc.**

No.12, Ln.12, Anzhong st., Luzhu Dist.,  
Taoyuan City, Taiwan  
Tel. +886-3-2121-725 Fax. +886-3-2127-960

[www.formaxpa.com](http://www.formaxpa.com)  
[www.formax88.com](http://www.formax88.com)



2024-8 All rights reserved.