

FORMAX®

HERE BEGINS YOUR ULTIMATE VALUE

FGB Series
Gravimetric Blender

FGB-54



Please read the brochure carefully before operation.

■ Coding Principle

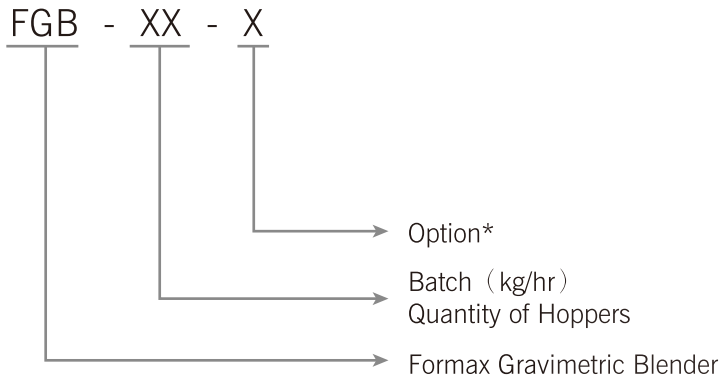

FGB-107

■ Features

Standard Configuration

- The micro scale metering accuracy is $\pm 0.1\%$ when Call materials are blended through gravity.
- Auto calibration functions which is performed every time after material weighting ensures best proportioning accuracy.
- Up to 100 recipes can be stored for future use.
- Include alarm history record function.
- FGB-5 and models below are directly mounted on machines (incl. magnetic base).
- For FGB-10 and models above, floor stand is the standard supply (equipped with floor stand, material storage tank, material control valve and suction box).
- Adopt Ethernet communication function to realize online centrally monitor function.
- Equipped with automatic suction control function.

Options

- Hopper low material level sensor is optional for advance warning when lacking materials.
- For mounting FGB-1/2/5 on the floor directly, the floor stand, material storage tank, material control valve and suction box should be equipped.
- Optional micro screw metering for metering materials from 0.2% to 0.5%
- Optional special material bridging breaker for film, sheet or irregular crushing and recycling
- Optional USB data collection function can read actual additive proportion, output, all kindly of materials' total amount and output rate of every lot of virgin, regrind, master batch and additives.

With Respect to Batch Capacity:

Ratios of masterbatch and additive are calculated with respect to Batch Capacity.

Example: batch=1000g

Main Hopper=Auto calculated, Hopper 1=40%, Hopper 2=3%, Hopper 3=2%.

The real weights are:

Main Hopper (Virgin)=1000g(100%-40%-3%-2%)=550g

Hopper 1 (Regrind)=1000g(40%)=400g

Hopper 2 (Masterbatch)=1000g(3%)=30g

Hopper 3 (Additive)=1000g(2%)=20g

Under this mode, weights of Matertach and Additive won't be fluctuated by Virgin of main hopper.



Home Screen

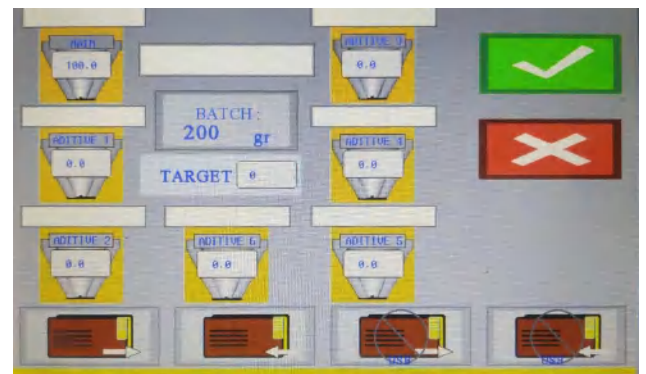

Recipes

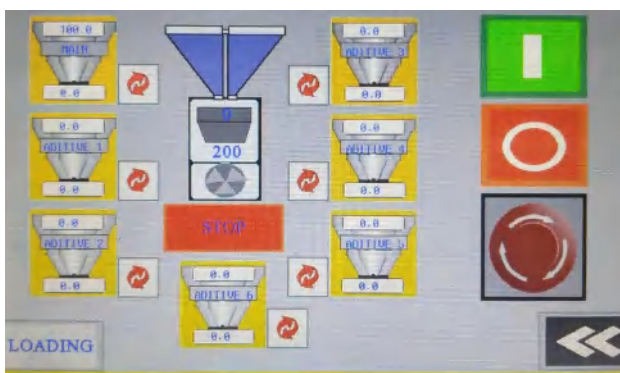

Weighing Monitor Screen

NO.	DATE	TIME	UNIT	ADDTIVE 1	ADDTIVE 2	ADDTIVE 3	TOTALS
12	06-09-10	15:44	242	0	0	0	242
11	06-09-10	15:44	241	0	0	0	241
10	06-09-10	15:44	221	0	0	0	221
9	06-09-10	15:44	220	0	0	0	220
8	06-09-10	15:43	220	0	0	0	220
7	06-09-10	15:43	218	0	0	0	218
6	06-09-10	15:42	206	0	0	0	206
5	06-09-10	15:42	198	0	0	0	198
4	06-09-10	15:42	212	0	0	0	212
3	06-09-10	15:41	204	0	0	0	204
2	06-09-10	15:41	229	0	0	0	229

Measurement Monitoring Screen

TOTALS 2.73
 TARGET 0
 KG/H 0.00

RESET

■ Application

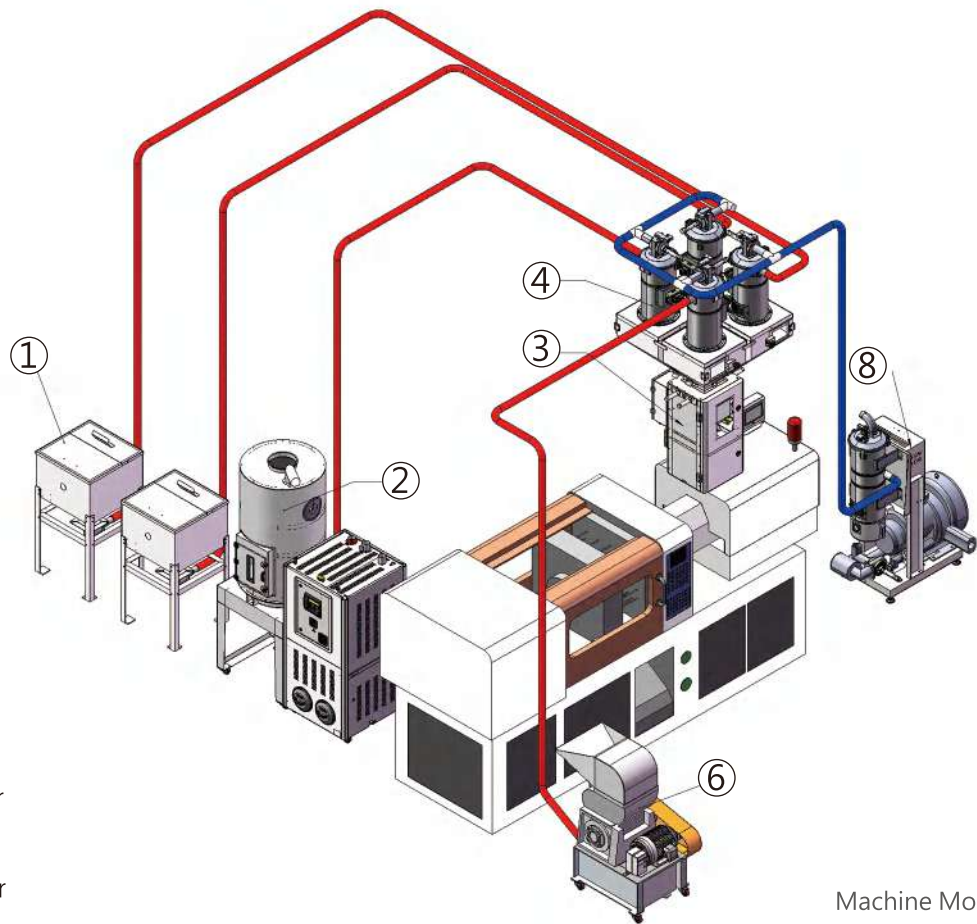

- ① Material Storage Tank
- ② 2-IN-1 Compact Dryer
- ③ Gravimetric Blender
- ④ Central Hopper Loader
- ⑤ Main Unit
- ⑥ Crusher
- ⑦ Three-phase Single Hopper Loader
- ⑧ SHY Series Main Unit (1VS4)

Machine Mounting

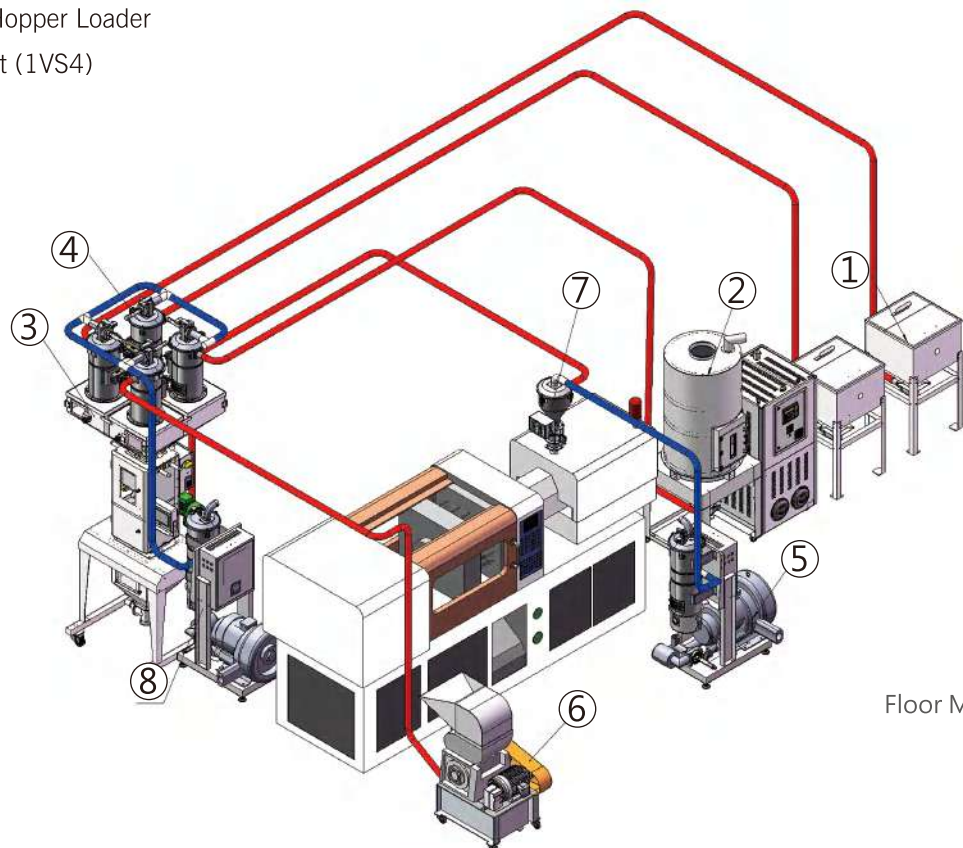

Floor Mounting

■ Working Principle

When machine starts working, main hopper starts feeding on the basic calculation of set weight and unit time feeding and then load cell will starts work. Withing the error range, the machine will go to hopper 1, and then in succession hopper 2, until all the hoppers finish feeding. Afer feeding, materials will fall into the mixing chamber and be blended until reaching the time limit. Manually open the shut-off plate or auotmatically open the material contorl valve to let the matieral fall into the process machine or storage tank.

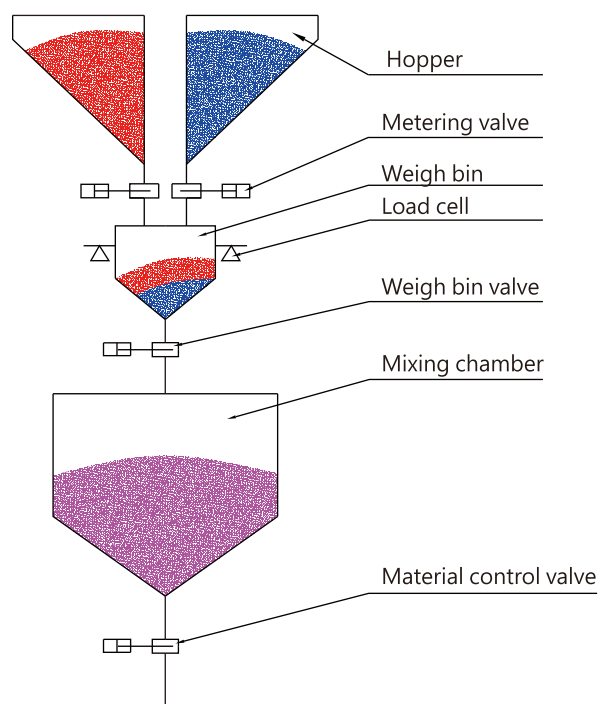

■ Options

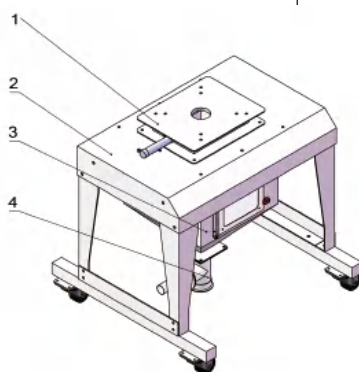
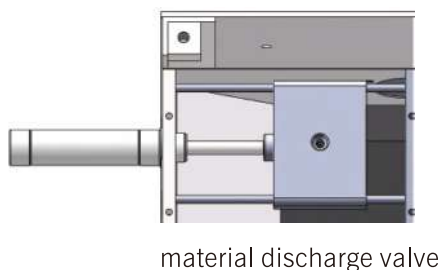

- ① Material Control Valve
- ② Movable Floor Stand
- ③ 50L Storage Tank
- ④ Suction Box

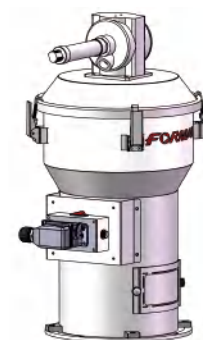
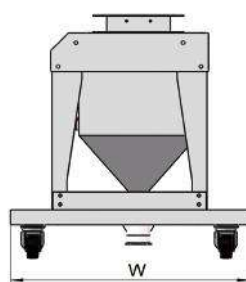
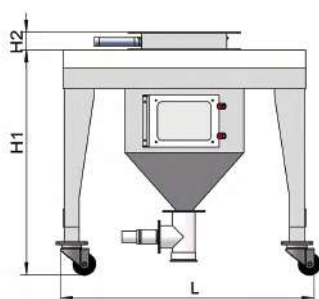

Central Hopper Loader

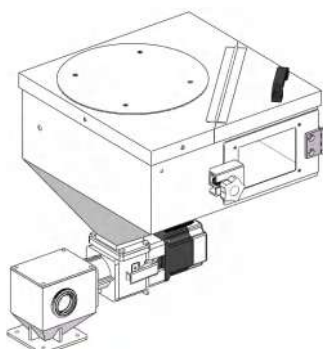

Option : Applicable models FGB1~5, requirement any additive proportion is less than 2% or high precision dosing, can be optional screw dosing units.

■ SHY Specifications

Model		Main Unit	Power (kw)	Central Hopper Loader	Hopper Capacity (L)	Material Pipe (inch)	Air Pipe (inch)
FGB-1	-2	SHY-CP3-M2	1.5	C3-T	3	1.5	2
	-4	SHY-CP6-M2	1.5	C6-T	3	1.5	2
FGB-2	-2	SHY-CP3-M3	4	C12-T	6	1.5	2
	-4	SHY-CP6-M3	4	C12-T	6	1.5	2
	-6	SHY-CP6-M5	4	C12-T	6	1.5	2
FGB-5	-2	SHY-CP3-M3	4	C12-T	12	1.5	2
	-4	SHY-CP6-M3	4	C12-T	12	1.5	2
	-6	SHY-CP6-M5	4	C12-T	12	1.5	2
FGB-10	-4	SHY-CP6-M10	7.5	C24-T	24	2	2.5
	-6	SHY-CP6-M10	7.5	C12-T	12	1.5	2
FGB-18	-4	SHY-CP6-M10	7.5	C36-T	36	2	2.5
	-6	SHY-CP6-M10	7.5	C36-T	36	2	2.5
FGB-25	-4	SHY-CP6-M10	7.5	C48-T	48	2.5	3
	-6	SHY-CP6-M15	11	C48-T	48	2.5	3

Note: 1) "T" means the air pipe is T joint.
2) Voltage: 3Ø, 380VAC, 50/60Hz

Specifications are subject to change without prior notice.

■ Outline Drawings

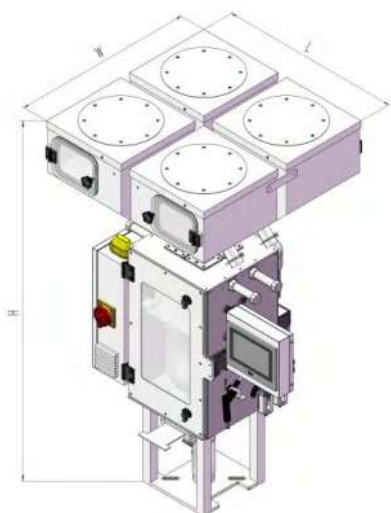

FGB1

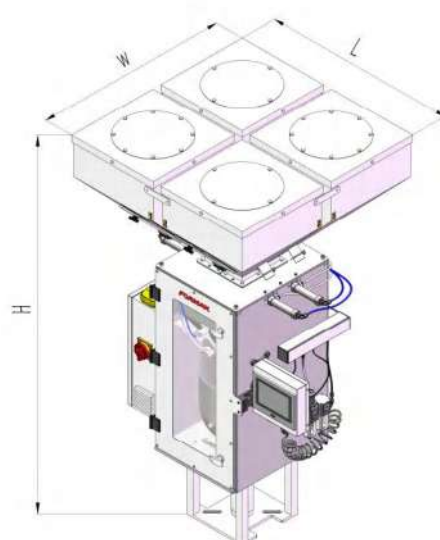

FGB2&FGB5

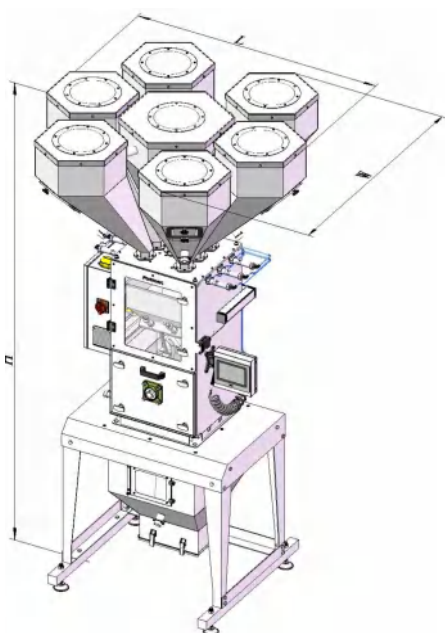

FGB10&FGB18

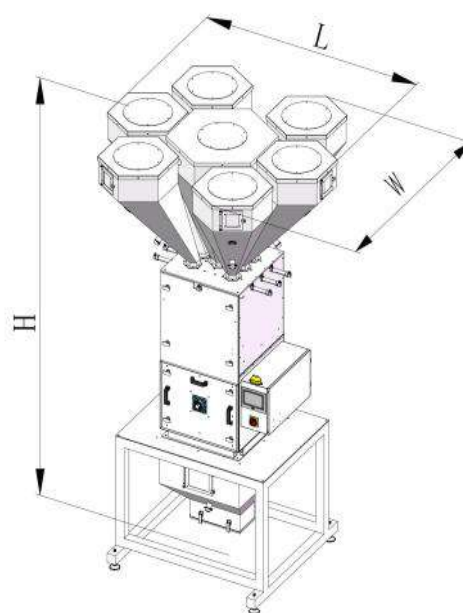

FGB25

Model	FGB-1	FGB-2	FGB-5	FGB-10	FGB-18	FGB-25
L(mm)	647	843	843	1370	1370	1750
W(mm)	697	892	892	1340	1340	1663
H(mm)	920	1180	1280	2600	2725	2880
Magnetic Base (mm) (LxWxH)	140x140x195	190x190x195	190x190x195	N/A	N/A	N/A
Floor Stand (mm) (LxWxH1xH2)	654x600x713x50 (Option)	814x800x885x60 (Option)	814x800x885x60 (Option)	930x930x900x60	930x930x900x60	1240x1240x1075x70
Net Weight (kg)	50~60	65~85	75~95	135~160	140~175	155~180

Specifications are subject to change without prior notice.

■ Specifications

Model	Component (STA.)	Max. Output (kg/hr)	Hopper Capacity (Ltr)	Weigh Batch (kg)	Weigh Capacity (Ltr)	Mixing Motor (kW)	Mixing Chamber (Ltr)	Voltage
	STA.	kg/hr	Ltr	kG	Ltr	kW	Ltr	
FGB-1	2	130	17	1	5	0.12	6	3Ø, 380VAC 50/60Hz
	3	110						
	4	90						
FGB-2	2	260	33	2	6.5	0.37	15	
	3	230						
	4	210						
	5	205						
	6	195						
FGB-5	2	840	33	5	12	0.37	15	
	3	740						
	4	670						
	5	650						
	6	600						
FGB-10	2	1860	52/70 (middle)	10	28	0.55	35	
	3	1625						
	4	1440						
	5	1310						
	6	1190						
	7	1100						
FGB-18	2	2400	52/70 (middle)	18	42	0.55	35	
	3	2200						
	4	2000						
	5	1800						
	6	1700						
	7	1600						
FGB-25	2	2890	70	25	56	0.75	65	
	3	2740						
	4	2530						
	5	2350						
	6	2200						
	7	2060						

Note: 1) The above data is based on continuous running of even particles whose bulk densities are 0.65kg/L and diameters are 3~4mm. The values vary along material features. Please further discuss if the material is not sure.

- The main metering valve is suitable for proportion not lower than 5 % and raw material of even particles or regrind of even particles whose diameters are within 6*6*6mm.
- The secondary metering valve is suitable for proportion of 0.5%~5% and master batch of even particles or additives whose diameters are within 4*4*4mm.
- Optional special material bridging breaker for film, sheet or irregular crushing and recycling whose diameters are within 12*12*12mm.
- Mixing and ration deviation refers to the difference between the setting percent and actual percent of each group. The micro scale metering accuracy can reach to $\pm 0.1\%$.
- Mixing motor voltage is 3Ø, 380VAC, 50/60Hz.

Specifications are subject to change without prior notice.

FORMAX®

China
Formax Plastics Automation, Inc.

Dongguan
No. 9, Taida Road, Chang'an Town, Dongguan City,
Guangdong Province, China
Tel. +86-769-3899-9898 Fax. +86-769-8533-3467

Kushan
No.138-20, Hengshan Road, Kunshan, Jiangsu, China
Tel. +86-512-5700-8308 Fax. +86-512-5700-8306

Taiwan
Formax Equipment Inc.

No.12, Ln.12, Anzhong st., Luzhu Dist.,
Taoyuan City, Taiwan
Tel. +886-3-2121-725 Fax. +886-3-2127-960

www.formaxpa.com
www.formax88.com



2024-8 All rights reserved.