

FORMAX®

HERE BEGINS YOUR ULTIMATE VALUE

FPV Series
Proportional Valve

FPV

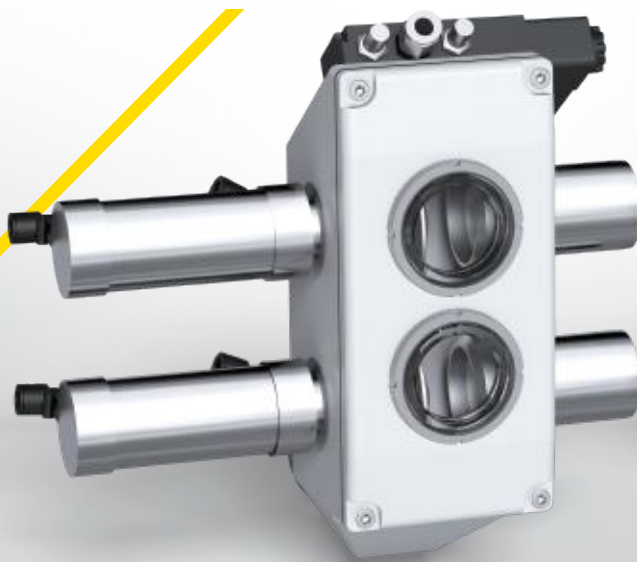

Please read the brochure carefully before operation.

FPV Series Proportional Valve

■ Coding Principle

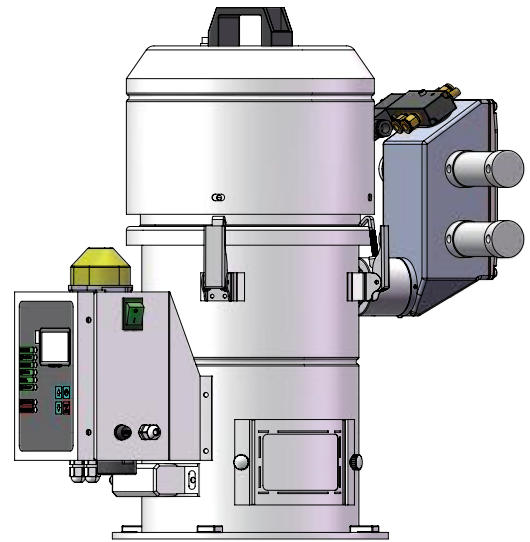
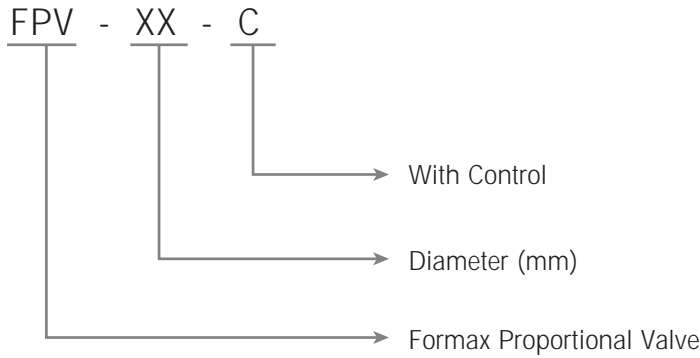

■ Features of this machine

Standard Configuration

- European style, beautiful appearance, convenient installation and simple operation.
- The unique valve body design makes material delivery more smoother.
- The solenoid valve performance is stable, cylinder movement is accurate, ensuring accurate mixing ratio.
- No need to have the control box when using with E-type European series vacuum loader.
- Applicable to the immediate recycling of crushed materials, which can reduce the cost of expenditure.
- 1-4 layers of working mode selection function to make the mixing more uniform.

Options

- In other occasions, you can choose the control box to use.

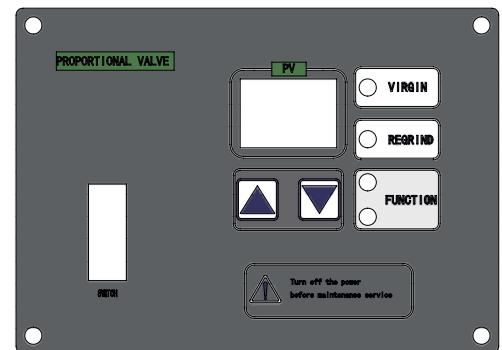

FPV-C Control Controller (Optional)

■ Application

- ① Material Tank
- ② Proportional Valve
- ③ E-Type Vacuum Loader
- ④ Granulator

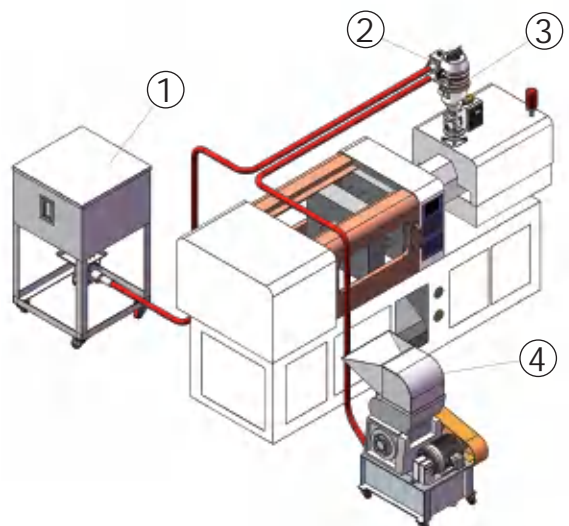

Working Principle

When the vacuum time and the secondary material ratio are set, the cylinder pushes the stopper 1, the stopper 2 closing and opening to control the proportion of raw materials and secondary materials for entering to the hopper loader, to achieve the purpose of proportional mixing

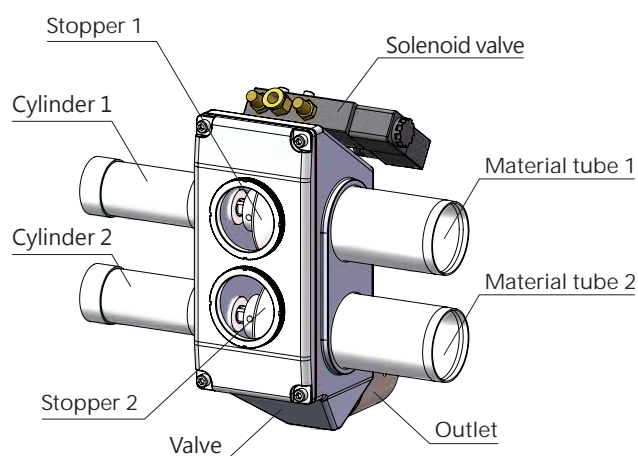

Outline Drawings

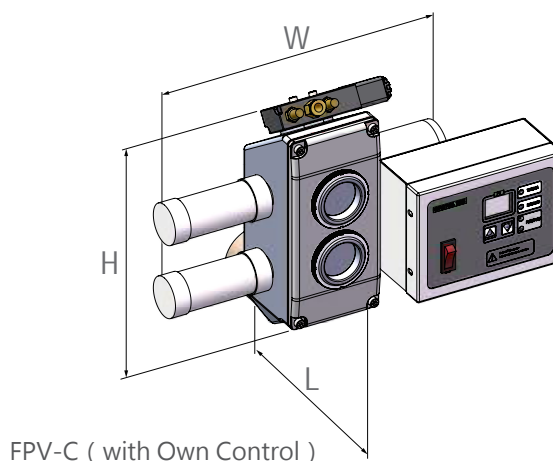
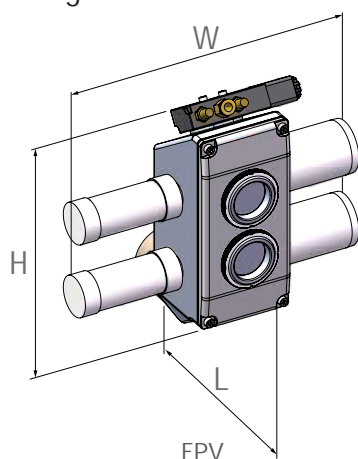

Specifications

Model	Driving force	Drive mode	Maximum throughput	Material Tube (inch)	Outline Dimensions(mm) H×W×L	Net Weight(Kg)
FPV-40	3Kg/cm ² High pressure air	Cylinder	350Kg/hr	1.5	240×245×150	3.0
FPV-50	4Kg/cm ² High pressure air	Cylinder	350Kg/hr	2	240×245×150	3.2

Notes:

- 1) With E/S+M vacuum loader including FPV Control, need option, add "C" after Model.
- 2) All output capacities of above models are based on data from bulk density.
- 3) Power supply: 1 , 230VAC, 50Hz

Specifications are subject to change without prior notice.

FORMAX®

China
Formax Plastics Automation, Inc.

Dongguan
No. 9, Taida Road, Chang'an Town, Dongguan City,
Guangdong Province, China
Tel. +86-769-3899-9898 Fax. +86-769-8533-3467

Kushan
No.138-20, Hengshan Road, Kunshan, Jiangsu, China
Tel. +86-512-5700-8308 Fax. +86-512-5700-8306

Taiwan
Formax Equipment Inc.

No.12, Ln.12, Anzhong st., Luzhu Dist.,
Taoyuan City, Taiwan
Tel. +886-3-2121-725 Fax. +886-3-2127-960

www.formaxpa.com
www.formax88.com



2022-12 All rights reserved.