



- Feeding and Conveying Equipment
- Drying and Dehumidifying Equipment
- Dosing and Mixing Equipment
- Heating and Cooling Equipment
- Granulator and Recycling Equipment

HERE BEGINS YOUR ULTIMATE VALUE

www.formaxpa.com

FORMAX®

Taiwan
Formax Equipment Inc.
 Tel. +886-3-2121-725 Fax. +886-3-2127-960

China
Formax Plastics Automation, Inc.

Dongguan
 Tel. +86-769-3899-9898 Fax. +86-769-8533-3467

Kushan
 Tel. +86-512-5700-8308 Fax. +86-512-5700-8306

www.formaxpa.com



üCloud

Design by Polaris 2018-03-+886-4-24517070

FORMAX®

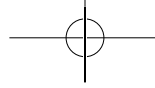

HERE BEGINS YOUR ULTIMATE VALUE



About FORMAX

Upholding the motto of Be committed to the minimal detail for the maximal value of each client since the founding in 1992, FORMAX has been committed to design and making of plastic peripherals and aided units, including the central feeding convey system, the desiccant dryer system, the weighing and mixing system, the cool-heat exchanging and grinding/recycling equipment, and the latest automatic integration system. FORMAX is the best partner trusted by global plastic processing businesses due to self demanding and cutting-edge technology.

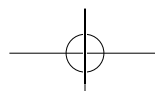
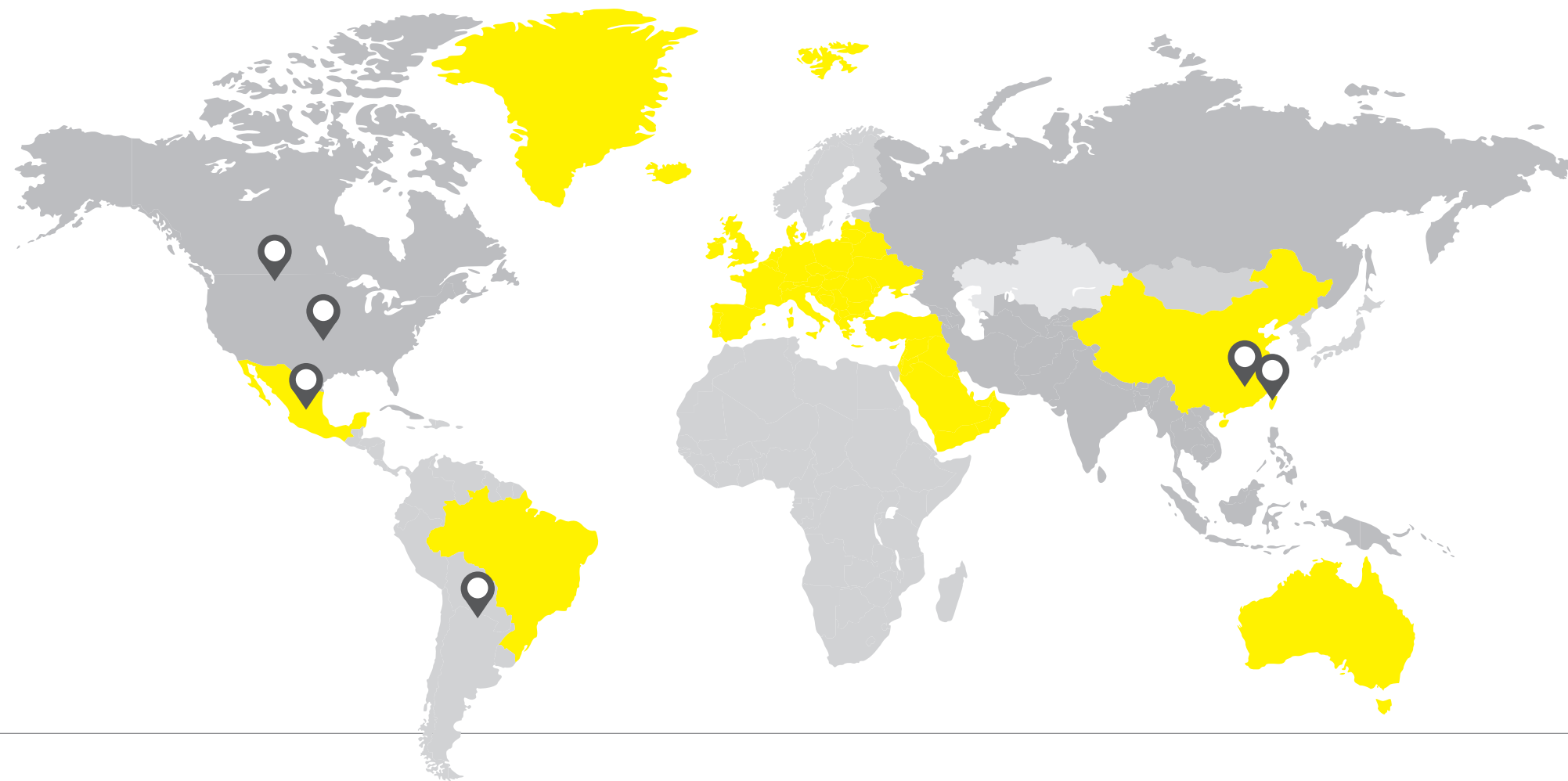

HERE BEGINS YOUR ULTIMATE VALUE



History of FORMAX

Keeps moving forward and improving

FORMAX keeps improving out of dissatisfaction to the current state and moving forward to the objective of Creating maximal values for clients by leaving the comfort zone behind. In pursuit of the best and the top, we are committed to constant improving and moving forward.

History of FORMAX

1992



2012



2014



2015



Activating FORMAX to create maximal values as the core of design reserves the significance of the totem: Activation.  The italics and fluent periphery lines empower the trademark and symbolize the technology and services with high standards supplied by FORMAX.

Best partner of global plastic processing businesses

Tailor-made solution

It is crucial to tackle each issue via a specific solution. It is our expertise to supply the fittest cost-effective solution to your demands, budget, limits and sizes of the project on the basis of rich experience.

Integration across fields

FORMAX is good at not only expertise in peripherals but also features of other facilities. It is our profession to supply full integration of technology and equipment from the central feeding system to the whole-plant planning.

Excellent technology

Simplicity is never simple. Each peripheral seemingly small is pretty vital to batch saving, power saving and smooth operation since each part made by FORMAX requires dense skills.

Quality valued the most

The peripherals need to be run stably by the least power consumption that depends on the finest quality. FORMAX that values Quality the most is a firm partner trusted by each client.

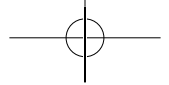

HERE BEGINS YOUR ULTIMATE VALUE

PRODUCTS



1 Granulator and Recycling Equipment

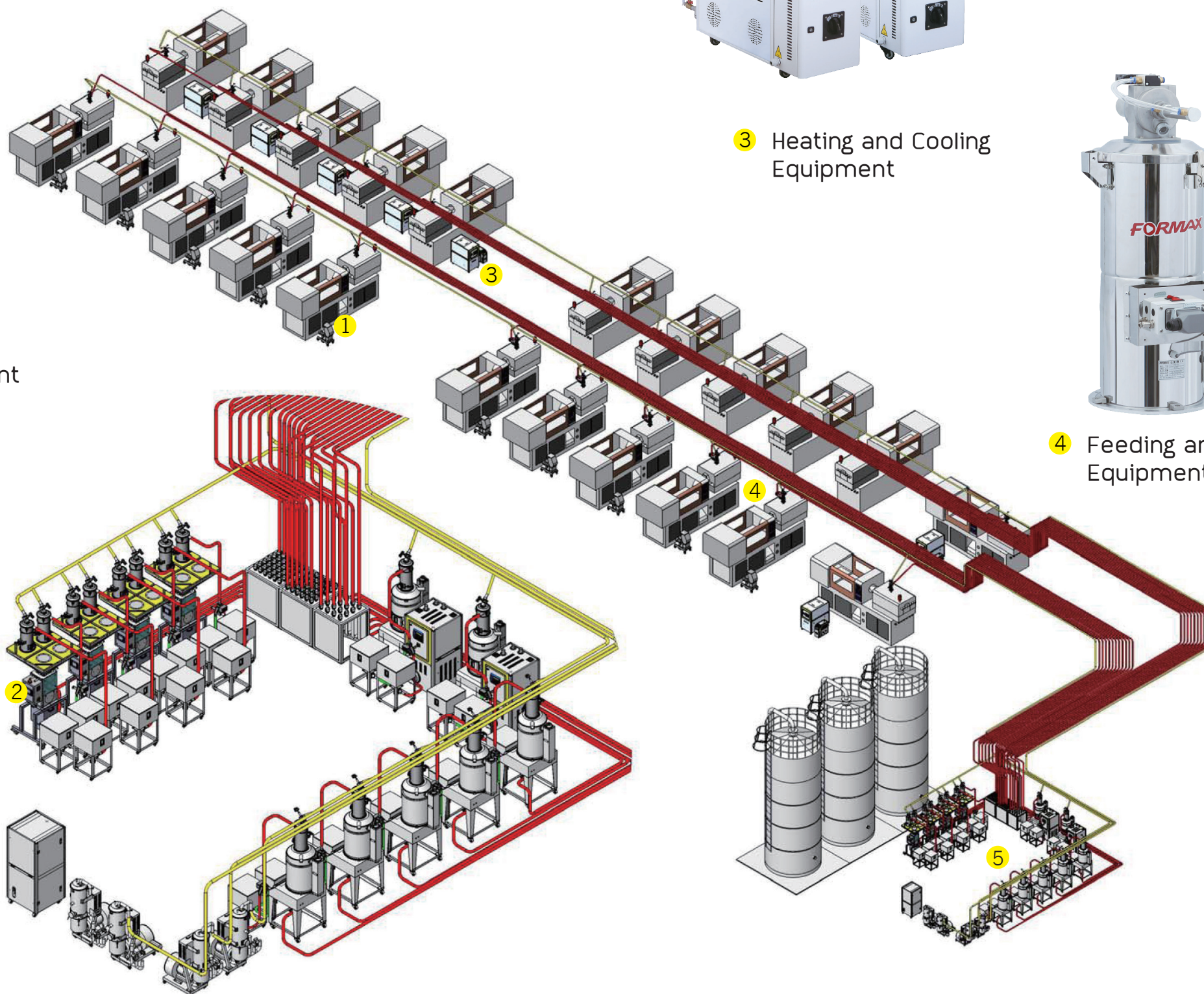

3 Heating and Cooling Equipment



4 Feeding and Conveying Equipment



2 Dosing and Mixing Equipment



5 Drying and Dehumidifying Equipment

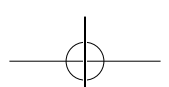

INDEX

07 Feeding and Conveying Equipment

- 08 E(EV) Series Single-phase Single Hopper Loaders
- 09 S(SV) Series Three-phase Single Hopper Loaders
- 10 SHY Series Single Wire Conveying System
- 12 C(CV) Series Central Hopper Loaders
- 14 SP Series Hopper Loader For Free-Flowing Powders
- 15 SN Series Hopper Loader for Non-Free-Flowing Powders
- 16 FV Series Venturi Loaders

17 Drying and Dehumidifying Equipment

- 18 FHD Series Hopper Dryers
- 20 HCD Series Honeycomb Dehumidifiers
- 22 FDL Series 2-in-1 Hot Air Compact Dryers
- 23 FCD Series 3-IN-1 Compact Dryers
- 24 FCD-HL Series Heatless Compact Units
- 25 FDD Series 2-in-1 Compact Dryers
- 26 FCAD Series Compressed Air Dryer

27 Dosing and Mixing Equipment

- 28 FVS Series Volumetric Screw Dosers
- 29 FVS Series Volumetric Screw Dosers
- 30 FGS Series Gravimetric Screw Dosers
- 31 FGB Series Gravimetric Blenders
- 32 FWM Series Gram Per Meter
- 33 FLC Series Gravimetric Liquid Color
- 34 FPV Series Proportional Valve

35 Heating and Cooling Equipment

- 36 FW Series Water Temperature Controllers
- 38 FO Series Oil Temperature Controllers
- 39 FCV Series Water or Oil Temperature Controllers
- 40 FOH Series H.T. Oil Temperature Controllers
- 41 FWC Series Water-cooled Chillers
- 42 FAC Series Air-cooled Chillers

43 Granulator and Recycling Equipment

- 44 FS Screenless Crusher
- 45 FG 180 Low speed Grusher
- 46 FG300 Medium Sized Crushers
- 47 FC300 Sound Proof Crushers



07

Feeding and
Conveying Equipment

E (EV) Series / Single-phase Single Hopper Loaders



- Full stainless steel construction.
- Fabric suction filter (with s/s mesh).
- Low noise suction head.
- E type is fitted with reed switch sensor, EV type is fitted with Photosensor. Equipped the mechanical flap, no need to adjust.
- All models include the Auto-filter cleaning as standard. It can set the cleaning time and cleaning frequency.
- Motor overload protection, and various alarm indicator.
- Electrical circuit built to comply with CE safety requirements.

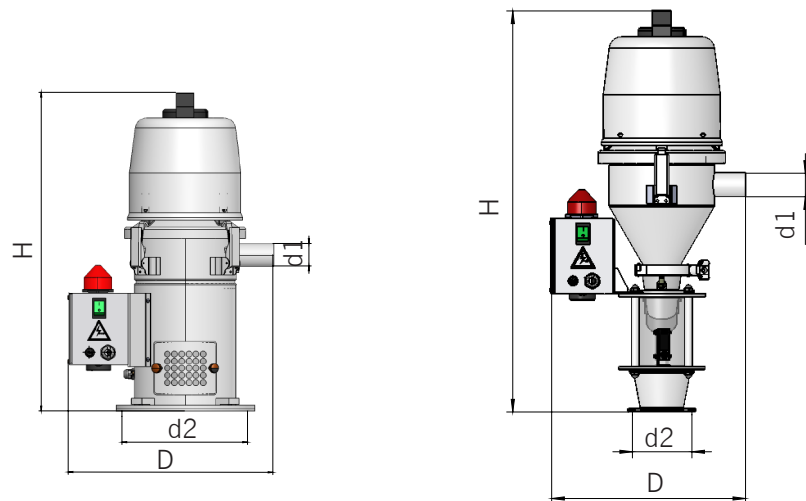

Specification

| Model | | E3 | E6 | E12 | EV3 | EV6 |
|------------------------|---------|---------|---------|---------|-----|-----|
| Hopper capacity | litre | 3 | 6 | 12 | 3 | 6 |
| Motor power | w | 1100 | | | | |
| Throughput | kg / hr | 70 | 140 | 200 | 70 | 140 |
| Probe diameter (d1) | inch | 1.5 / 2 | 1.5 / 2 | 1.5 / 2 | 1.5 | 1.5 |
| Mounting diameter (d2) | mm | 235 | 285 | 285 | 110 | 110 |
| Depth (D) | mm | 332 | 406 | 413 | 314 | 347 |
| Overall height (H) | mm | 505 | 615 | 761 | 615 | 735 |
| Weight approx. | kg | 12 | 13 | 15 | 13 | 14 |

S (SV) Series / Three-phase Single Hopper Loaders



- Full stainless steel construction.
- Fabric suction filter (with s/s mesh).
- S type is fitted with reed switch sensor, SV type is fitted with Photosensor. Equipped the mechanical flap, no need to adjust.
- Motor overload protection, and various alarm indicator.
- Cyclone filter as option.
- Electrical circuit built to comply with CE safety requirements.

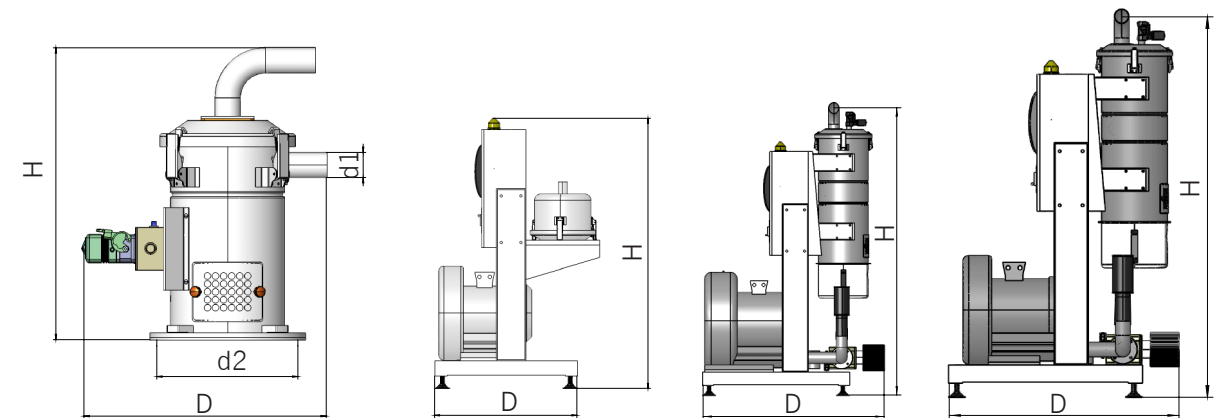

Specification

| Model | | S3 | S6 | S12 | S25 | S50 | SV3 | SV6 |
|------------------------|-------|-----|---------|---------|---------|---------|-----|---------|
| Hopper capacity | litre | 3 | 6 | 12 | 25 | 50 | 3 | 6 |
| Probe diameter(d1) | inch | 1.5 | 1.5 / 2 | 1.5 / 2 | 1.5 / 2 | 2 / 2.5 | 1.5 | 1.5 / 2 |
| Mounting diameter (d2) | mm | 235 | 285 | 285 | 360 | 520 | 110 | 110 |
| Depth (D) | mm | 364 | 404 | 418 | 520 | 550 | 312 | 347 |
| Overall height (H) | mm | 430 | 550 | 685 | 827 | 850 | 540 | 658 |
| Weight approx. | kg | 9 | 10 | 12 | 15 | 18 | 10 | 11 |

| Model | | M1 | M2 | M3 | M5 | M5D | M10 | M10D | M20D |
|----------------|----|------|-----|-----|-----|------|------|------|------|
| Blower power | kw | 0.75 | 1.5 | 2.2 | 4 | 5.5 | 7.5 | 7.5 | 15 |
| Throughput | kg | 250 | 400 | 500 | 750 | 1000 | 1000 | 1200 | 1500 |
| Width | mm | 480 | | | | | | | |
| Depth (D) | mm | 580 | | | | 680 | | | 900 |
| Height (H) | mm | 1100 | | | | 1330 | | | |
| Weight approx. | kg | 28 | 38 | 53 | 56 | 105 | 102 | 126 | 145 |

HERE BEGINS YOUR ULTIMATE VALUE

SHY Series Single Wire Conveying System



- 1 SHY Main Controller
- 2 Central Hopper Loaders
- 3 MIH
- 4 MST

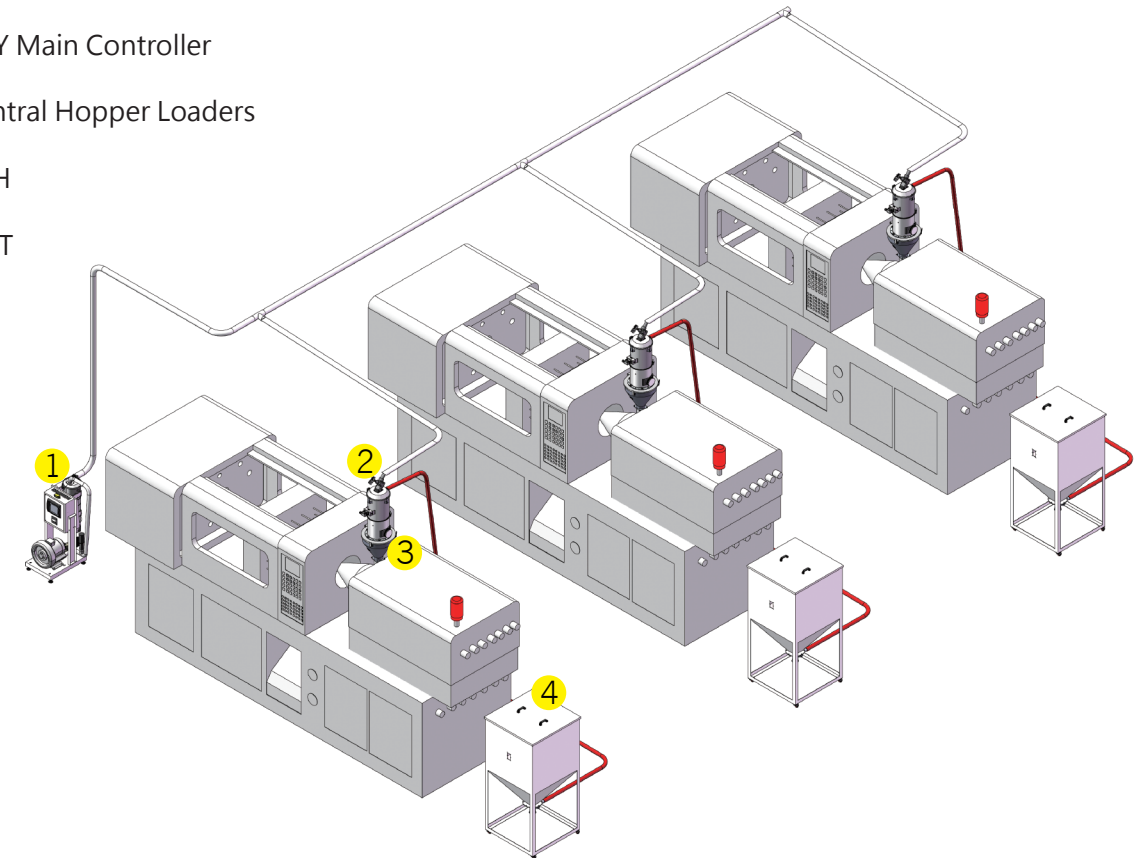

- With up to 12 stations of material conveying, it can greatly lower the cost.
- With lower suction type design and filter with cyclone baffle plate below it mounted in the separating dust collector, it can reduce the load of filter effectively.
- Separating dust collector is convenient for dust cleaning.
- Equipped with faults and motor overload indicators, the main machine can give an alarm immediately.
- All main machines are equipped with vacuum valve to protect the blower.
- With central operation panel, it can centrally set parameters of loading material for each station.
- With distributed bus control, it can save cables and is easy to construct as well as to maintain.



SHY-M2~M5

SHY-M10~M20D

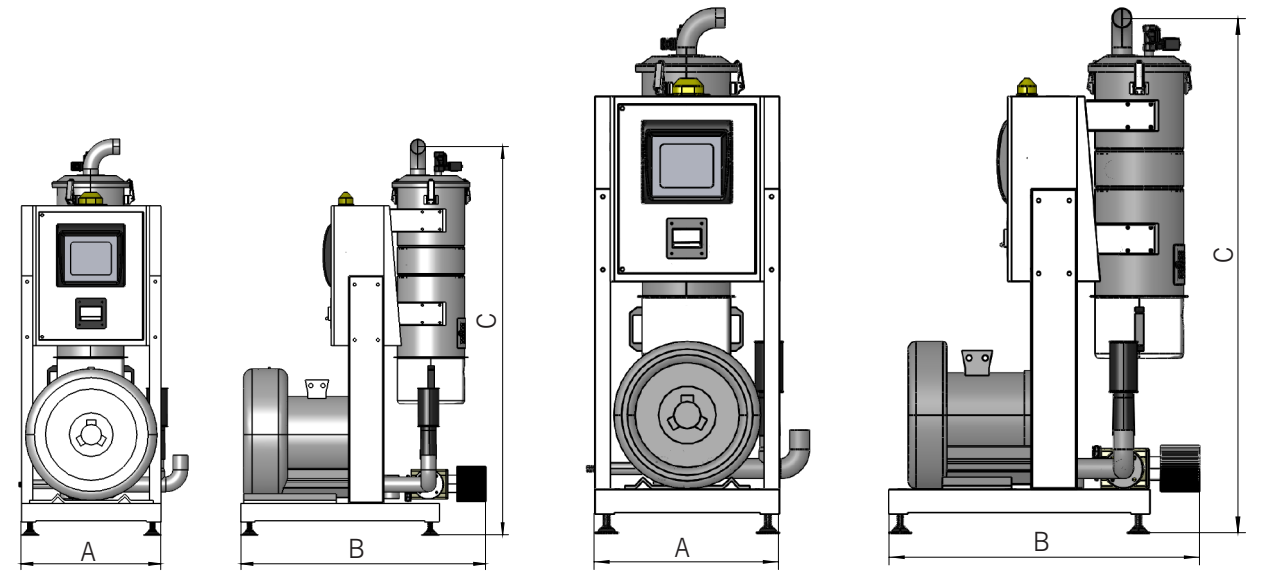

Specification

| Model | | SHY-M2 | SHY-M3 | SHY-M5 | SHY-M5D | SHY-M10 | SHY-M10D | SHY-M20D |
|----------------|----|--------|--------|--------|---------|---------|----------|----------|
| Blower power | kw | 1.5 | 2.2 | 4 | 5.5 | 7.5 | 7.5 | 15 |
| Throughput | kg | 400 | 500 | 750 | 1000 | 1000 | 1200 | 1500 |
| Width | mm | 480 | | | | | | |
| Depth | mm | 580 | | | 840 | | | 900 |
| Height | mm | 1100 | | | 1330 | | | 1750 |
| Weight approx. | kg | 38 | 53 | 56 | 102 | 105 | 126 | 145 |
| CP3 | - | CP3 | | | | | | |
| CP6 | - | CP6 | | | | | | |
| CP12 | - | CP12 | | | | | | |

HERE BEGINS YOUR ULTIMATE VALUE

C (CV) Series Central Hopper Loaders



C Series Central loaders use a unique cyclone device to collect the dust. This Series are fitted with a reed switch to sense the material level, together with non-return flap valves on both the material inlet and discharge ports.

CV Series is fitted with a photo sensor to sense the material level, together with non-return flap valves on both the material inlet and discharge ports. This series of hopper loader is particularly suitable for mounting directly onto the machine feed throat.

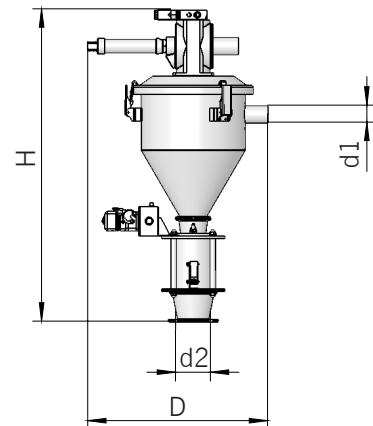
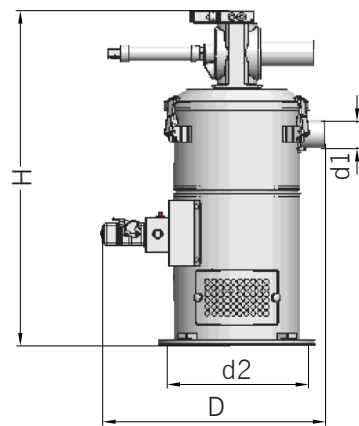

Specification

| Model | | C3 | C6 | C12 | C25 | C50 | C75 | C100 | CV3 | CV6 |
|------------------------|-------|-----|---------|---------|---------|---------|---------|---------|-----|---------|
| Hopper capacity | litre | 3 | 6 | 12 | 25 | 50 | 75 | 100 | 3 | 6 |
| Probe diameter (d1) | inch | 1.5 | 1.5 / 2 | 1.5 / 2 | 2 / 2.5 | 2.5 / 3 | 2.5 / 3 | 2.5 / 3 | 1.5 | 1.5 / 2 |
| Mounting diameter (d2) | mm | 235 | 285 | 285 | 360 | 360 | 360 | 360 | 110 | 110 |
| Depth (D) | mm | 370 | 409 | 450 | 496 | 558 | 630 | 754 | 304 | 383 |
| Overall height (H) | mm | 523 | 632 | 782 | 980 | 1145 | 1182 | 1120 | 578 | 648 |
| Weight approx. | kg | 9 | 14 | 15 | 20 | 30 | 50 | 70 | 9 | 14 |

Optional Accessories

BS Vacuum Pump

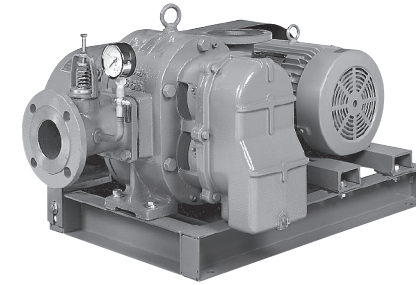

EPV Electronic Pressure Valve



F Safety Filter Dust Collector



MCV Material Cleaning Valve

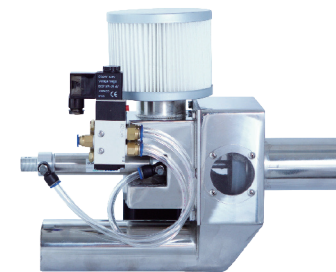

PB Power Control Box



MPV Mechanical Pressure Valve



CP Centralized Control Panel



MIH Material Intermediate Hopper

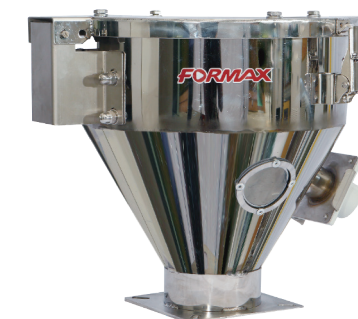

SP Series

Hopper Loader For Free-Flowing Powders



- The unit is designed for dust-free operation with using the Teflon filter Bag. Filter efficient is 1 μ . It is suitable to convey all free-flowing powder.
- Modules are designed for easy filter replacement and ensure unit the optimum easy cleaning. No tools needed for material changes or clean out.
- The control panel can be either mounted on the hopper loader as standard or installed on the vacuum unit.
- A self-closed flap mechanism with magnetic switch is fitted to the material discharge port underneath the hopper, no need adjustment.
- There is a cleaning door with a filter cartridge fitted with hopper body in order to assist operation and maintenance of flap mechanism.
- Purge a compressed air in the filter at a time, to clean and get rid of impurities which attribute excellent conveying performance and eliminate material packing.

Specification

| Model | | SP6 | SP25 | SP50 | SP100 |
|-----------------|----------------------|------|------|------|-------|
| Hopper capacity | litre | 6 | 25 | 50 | 100 |
| Filter surface | m ² | 0.30 | 0.42 | 0.54 | 0.66 |
| Compressed air | kg / cm ² | 2~3 | | | |
| Probe diameter | inch | 2 | 2 | 2.5 | 3 |
| Width | mm | Ø265 | Ø360 | Ø420 | Ø500 |
| Overall height | mm | 933 | 1100 | 1567 | 1826 |
| Weight approx. | kg | 20 | 35 | 45 | 60 |

SN Series

Hopper Loader For Non-Free-Flowing Powders

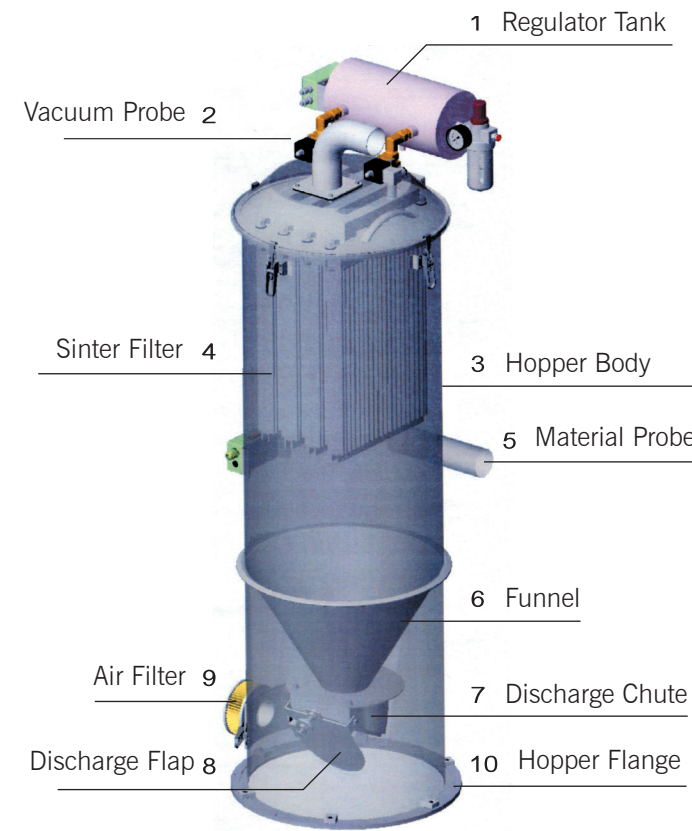

- High dense-phase vacuum conveying for fine powders. Use "Sinter-plate" filters separation efficient up to 99.999%, and clean gas side particulate content ≤ 1 mg/m³ S.T.P.
- Impact, anti-corrosive anti-statistic, water-proof and long working life, etc.
- Fast assembly and disassembly for cleaning. quick and easy module replacement.
- Special design, lower air-purge consumption, and best air-purge cleaning efficiency.
- Purge a compressed air in the filter at a time, to clean and get rid of impurities which attribute excellent conveying performance and eliminate material packing.

Specification

| Model | | SN25 | SN50 | SN100 |
|-----------------|----------------------|------|------|-------|
| Hopper capacity | litre | 25 | 50 | 100 |
| Filter surface | m ² | 1.1 | 2.2 | 3.3 |
| Compressed air | kg / cm ² | 2~3 | | |
| Probe diameter | inch | 2 | 2.5 | 3 |
| Width | mm | Ø350 | Ø420 | Ø500 |
| Overall height | mm | 1370 | 1567 | 1826 |
| Weight approx. | kg | 40 | 65 | 80 |

HERE BEGINS YOUR ULTIMATE VALUE

FV Series

Venturi Loaders

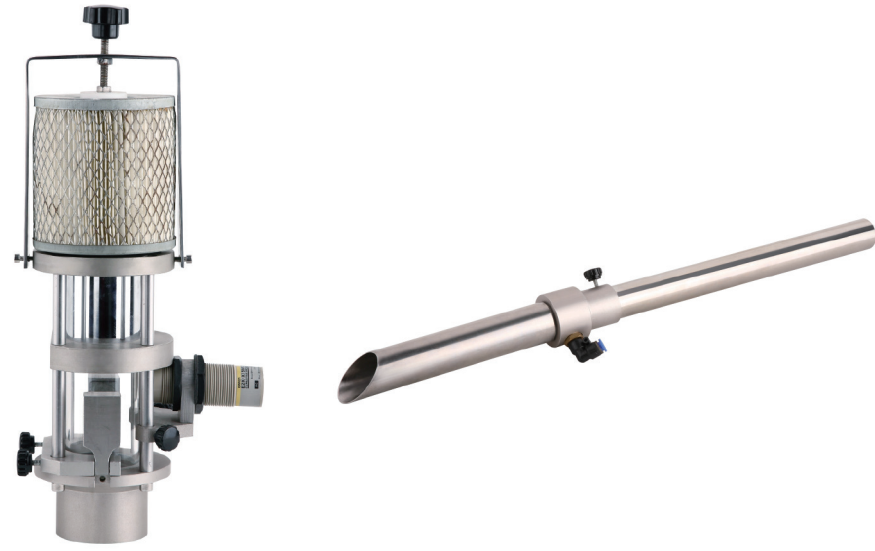

- European Type appearance, compact in size and light-weighted. Capacitive sensor mounted onto the glass-tube for accurate level sensing
- Filtered air exhaust does not pollute environment.
- Silent operation, it uses high-pressure air to convey materials.
- Quick installation and easy operation with surface polished.
- Hopper and base mount positions are adjustable.
- Easy access to material hopper for convenient cleaning.

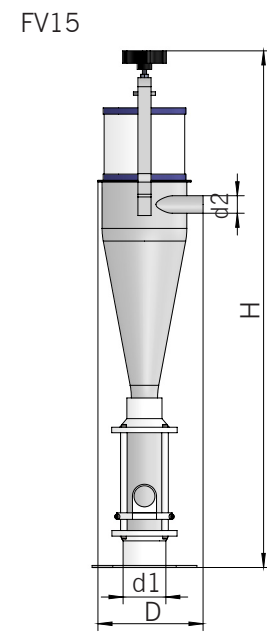
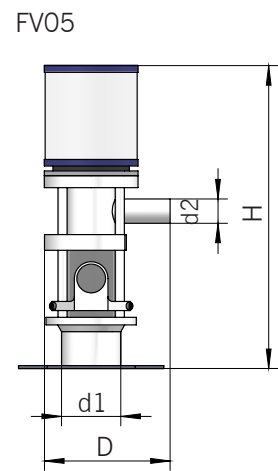

Specification

| Model | | FV05-25 | FV15-25 |
|------------------------|----------------------|---------|---------|
| Hopper capacity | Liter | 0.5 | 1.5 |
| Compressed air | kg / cm ² | 4 ~ 6 | |
| Height (h) | mm | 315 | 750 |
| Width (d) | mm | 132 | 153 |
| Probe diameter (d2) | mm | 25 | |
| Mounting diameter (d1) | mm | 62 | |
| Weight approx. | kg | 5.5 | 6 |
| Throughput | kg/hr | 40 | 60 |

Vertical height 3M, horizontal distance 6M.



17

Drying and Dehumidifying Equipment

HERE BEGINS YOUR ULTIMATE VALUE

FHD Series Hopper Dryers



- Full stainless steel internal parts.
- Drying under the principle of Hot air down-blowing and Cyclonic air exhausting which ensures consistent drying effects.
- Hopper lid prepared for easy mounting of hopper loader.
- Hopper cleaning door(FHD50 and above).
- All model offer rapid heating and accurate PID temperature controller.
- 7-day timer clock for auto start-up(FHD100 and above).
- Adjustable overheat safety thermostat.
- Main power isolator externally mounted as standard.
- Electrical circuit built to comply with CE safety requirements.

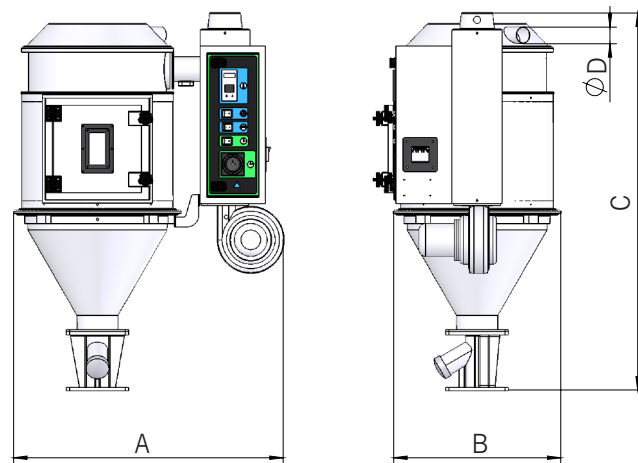

Specification

| Model | | 15 | 30 | 50 | 75 | 100 | 150 | 200 | 300 | 400 | 600 |
|----------------------|-------|---------------------------|-----|-----|------|------|------|------|------|------|------|
| Hopper capacity | litre | 25 | 50 | 85 | 115 | 170 | 230 | 335 | 460 | 670 | 1000 |
| Blower motor | W | 90 | 90 | 200 | 200 | 250 | 250 | 300 | 300 | 400 | 400 |
| Heating capacity | kw | 1.6 | 2.7 | 4 | 5 | 6 | 8 | 10 | 13 | 20 | 20 |
| Drying temp. range | °C | 150 (up to 180 as option) | | | | | | | | | |
| Voltage, three-phase | V | 220~460 | | | | | | | | | |
| Width (A) | mm | 590 | 665 | 755 | 755 | 835 | 835 | 970 | 970 | 1221 | 1321 |
| Depth (B) | mm | 420 | 455 | 510 | 510 | 590 | 590 | 710 | 710 | 900 | 1000 |
| Height (C) | mm | 635 | 820 | 940 | 1180 | 1240 | 1566 | 1550 | 1970 | 1833 | 2290 |
| Outlet port (D) | inch | 1.5 | 2 | 2 | 2 | 3 | 3 | 3 | 3 | 4 | 4 |
| Weight approx. | kg | 30 | 45 | 60 | 80 | 100 | 140 | 165 | 195 | 230 | 280 |

Optional Accessories

HB Hopper Base

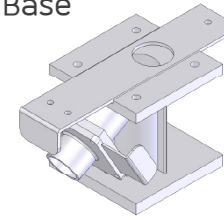

| Model | Available Type |
|--------|----------------|
| HB-15 | FHD-15 |
| HB-30 | FHD-30~75 |
| HB-100 | FHD-100~150 |
| HB-200 | FHD-200~300 |

MR Magnets

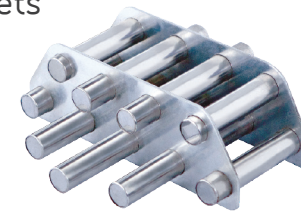

| Model | Available Type |
|--------|----------------|
| MR-15 | FHD-15~30 |
| MR-50 | FHD-50~150 |
| MR-200 | FHD-200~300 |

NFS N Type Floor Stands



| Model | Available Type |
|---------|----------------|
| NFS-15 | FHD-15~30 |
| NFS-50 | FHD-50~75 |
| NFS-100 | FHD-100~150 |
| NFS-200 | FHD-200~300 |

SB Suction Box

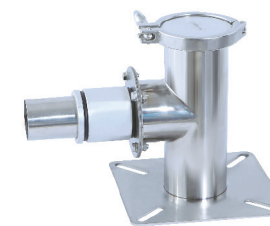

| Model | Available Type |
|----------|----------------|
| SB-1P-40 | FHD-15~75 |
| SB-1P-50 | FHD-100~300 |

MB Magnetic Base

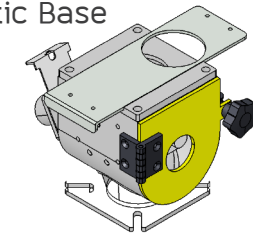

| Model | Available Type |
|--------|----------------|
| MB-15 | FHD-15~30 |
| MB-50 | FHD-50~150 |
| MB-200 | FHD-200~300 |

SGV Slide Gate Valve



| Model | Available Type |
|---------|----------------|
| SGV-15 | FHD-15~30 |
| SGV-50 | FHD-50~150 |
| SGV-200 | FHD-200~300 |

PFS Platform Stands



| Model | Available Type |
|---------|----------------|
| PFS-50 | FHD-50~75 |
| PFS-100 | FHD-100~150 |
| PFS-200 | FHD-200~300 |

SB-MS Material Shut Off Box

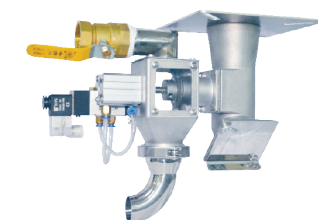

| Model | Available Type |
|-------------|----------------|
| SB-1P-40-MS | FHD-15~75 |
| SB-1P-50-MS | FHD-100~300 |

HERE BEGINS YOUR ULTIMATE VALUE

HCD Series Honeycomb Dehumidifiers



HCD Series of Honeycomb Dehumidifiers have been designed built using the "Rotor Honeycomb" principle, and operate in a closed loop system with the dew-point of -40 °C. The Honeycomb rotor is divided into a process and regeneration zones by the casing structure and heat resistance air sealing. The rotor is constantly and very slowly rotated at an optimum rotation speed for the condition by a gear motor. High moisture air is drawn into the honeycomb matrix of the rotor through the return air filter by the process blower. When the air is passing through the

honeycomb matrix, moisture in the air is absorbed and dried air is discharged from the process outlet by the process blower. The rotor absorbed moisture is rotated into the dehumidifying zone before it is saturated. At the same time, the cooling air is drawn from the counter side through the regeneration filter and is heated and enters the regeneration zone of the rotor and disturbs the moisture absorbed in the rotor and then is exhausted to the outside by a regeneration blower. This cycle of operation is continuously conducted.

Specification

| Model | HCD | 50 | 100 | 180 | 300 | 400 | 700 | 1000 |
|--------------------|------|--------------------------------|-------|-----|-------|-----|---------|------|
| Dewpoint | °C | -40 | | | | | | |
| Air flow | CMH | 50 | 100 | 180 | 300 | 400 | 700 | 1000 |
| Processing blower | kw | 0.55 | 0.75 | 1.9 | 2.6 | 3.7 | 7.5 | 11.3 |
| Regen. blower | kw | 0.25 | 0.55 | | 0.75 | | 2.25 | 3.75 |
| Regen. heater | kw | 2.5 | 4 | 5 | 6 | 8.5 | 15 | 22 |
| Processing way | | Honeycomb rotor | | | | | | |
| Rotor motor | kw | 0.015 | | | 0.025 | | | |
| System control | | PID auto tuning microprocessor | | | | | | |
| Processing outlet | inch | 2 | 2.5 | | 3 | | 6.5 | |
| Regen. outlet | inch | 1.5 | 2.5 | 2.5 | 3 | 3 | 3.5 | 3.5 |
| Cooling water flow | gpm | 1.5 | 3 | 6 | 9 | 12 | 21 | 30 |
| Water connect | inch | 1 / 2 | 3 / 4 | | 3 / 4 | | 1 1 / 4 | |
| Power supply | V | AC220~480V, 3P 50 / 60HZ | | | | | | |
| Control volt. | V | AC220V, 1P | | | | | | |
| Total power | kw | 3.4 | 3.4 | 7.5 | 9.4 | 13 | 24.8 | 37.1 |
| Dimension (mm) | W | 650 | 765 | | 900 | | 1250 | 1250 |
| | L | 745 | 910 | | 1045 | | 1400 | 1550 |
| | H | 1280 | 1630 | | 1930 | | 2085 | 2085 |
| Weight approx. | kg | 150 | 200 | 250 | 300 | 320 | 400 | 420 |

The Dehumidifying Principle

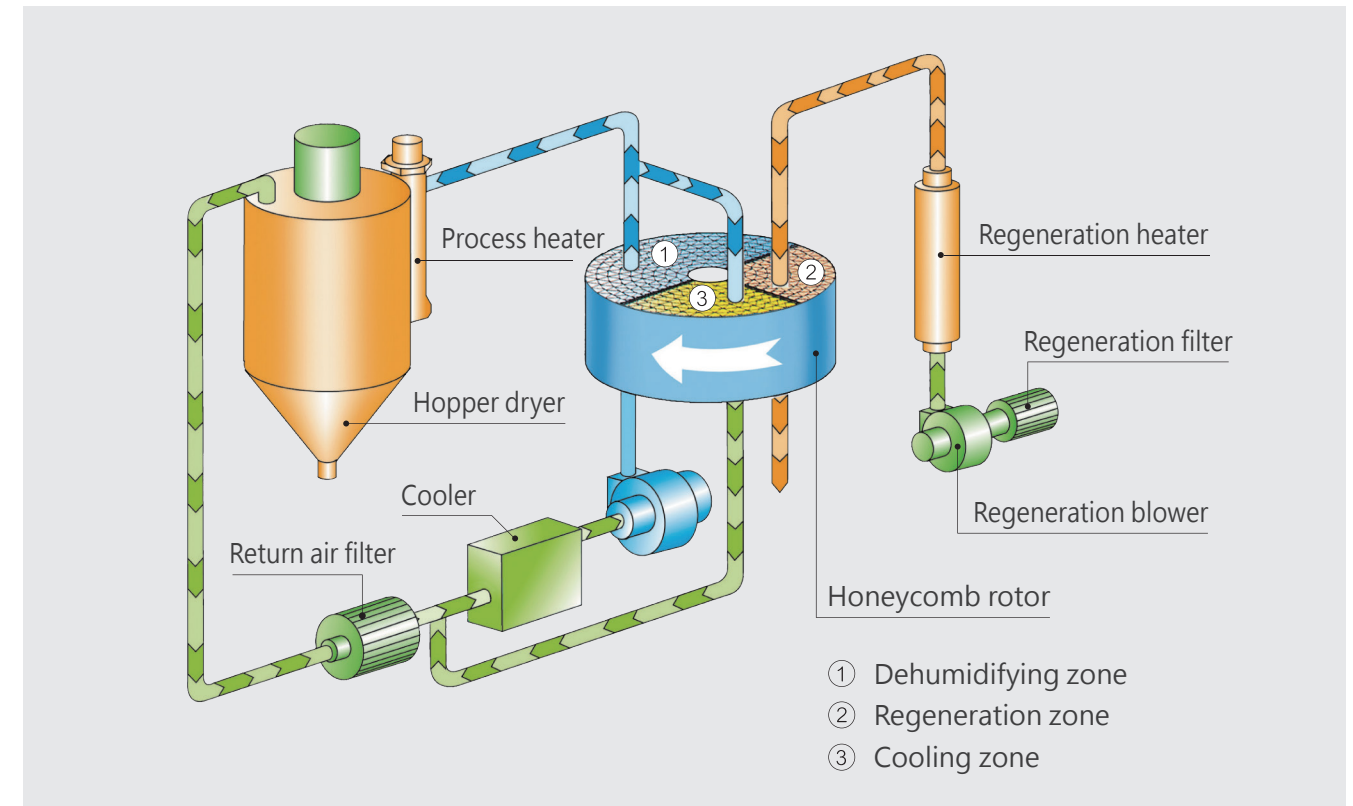

Drying Capacities Kg/hr

| Material | Drying Temp(°C) | Drying Time(hr) | Moisture Content(%) | Drying Capacity / HCD Model | | | | | | | | | | | |
|----------|-----------------|-----------------|---------------------|-----------------------------|-----|-----|-----|-----|-----|------|------|------|------|------|--|
| | | | | 50 | 100 | 180 | 300 | 400 | 700 | 1000 | 1300 | 1600 | 1900 | 2300 | |
| ABS | 80 | 3~4 | 0.4 | 30 | 60 | 100 | 165 | 220 | 390 | 560 | 730 | 895 | 1060 | 1260 | |
| POM | 100 | 2 | 0.3 | 30 | 60 | 105 | 180 | 240 | 420 | 600 | 780 | 960 | 1140 | 1375 | |
| PMMA | 80 | 2~3 | 0.4 | 30 | 60 | 105 | 175 | 230 | 405 | 580 | 755 | 930 | 1100 | 1330 | |
| LONOMER | 90 | 4~5 | ≤1 | 20 | 40 | 75 | 120 | 160 | 285 | 405 | 525 | 645 | 765 | 925 | |
| PA6 | 75 | 4~6 | ≤1 | 25 | 50 | 90 | 150 | 200 | 345 | 490 | 640 | 785 | 935 | 1130 | |
| PA6.6 | 75 | 4~6 | ≤1 | 25 | 50 | 90 | 150 | 200 | 345 | 490 | 640 | 785 | 935 | 1130 | |
| PA6.10 | 75 | 4~6 | ≤1 | 25 | 50 | 90 | 150 | 200 | 345 | 490 | 640 | 785 | 935 | 1130 | |
| PC | 120 | 3~4 | 0.3 | 25 | 45 | 75 | 130 | 170 | 295 | 420 | 550 | 675 | 675 | 800 | |
| PU | 90 | 2~3 | | 25 | 45 | 75 | 130 | 170 | 295 | 420 | 550 | 675 | 675 | 800 | |
| PBT | 130 | 3~4 | 0.25 | 20 | 35 | 60 | 100 | 135 | 235 | 335 | 435 | 535 | 635 | 770 | |
| PE | 90 | 1 | | 20 | 40 | 75 | 120 | 160 | 285 | 405 | 525 | 645 | 765 | 925 | |
| PET | 160 | 4~6 | 0.4 | 20 | 35 | 60 | 100 | 135 | 235 | 335 | 435 | 535 | 635 | 770 | |
| PETG | 70 | 3~4 | | 25 | 45 | 80 | 35 | 180 | 310 | 445 | 575 | 710 | 840 | 1050 | |
| PPO | 110 | 2 | 0.1 | 25 | 45 | 80 | 135 | 180 | 310 | 445 | 575 | 710 | 840 | 1050 | |
| PP | 90 | 1 | | 25 | 45 | 80 | 135 | 180 | 310 | 445 | 575 | 710 | 840 | 1050 | |
| PS (GP) | 80 | 1 | 0.1 | 30 | 60 | 105 | 180 | 240 | 420 | 600 | 780 | 960 | 1140 | 1375 | |
| PSU | 120 | 3~4 | 0.2 | 25 | 45 | 80 | 135 | 180 | 310 | 445 | 575 | 710 | 840 | 1015 | |
| PVC | 70 | 1 | 0.4 | 40 | 75 | 135 | 225 | 295 | 515 | 740 | 960 | 1180 | 1400 | 1695 | |
| SAM (AS) | 80 | 2 | 0.1 | 30 | 60 | 105 | 180 | 240 | 420 | 600 | 780 | 960 | 1140 | 1375 | |

FDL Series 2-in-1 Hot Air Compact Dryers



- Closed-loop conveying device eliminates the possibility of moisture regain during material conveying.
- Hot air recycler equipped as standard, featuring energy saving, no exhaust of hot air and dust, and environmental protection.
- Shut-off suction box equipped as standard ensures no material remains in the material line after each loading cycle.
- Double-wall drying hopper features hot air down-blowing and cyclonic exhaust design, it maintains a steady temperature and increase drying efficiency.

Specification

| Model | FDL | 30 | 50 | 75 | 100 | 150 |
|-----------------------------------|-------|--|------|------|------------------|------|
| Hopper dryer (double-wall) | litre | 50 | 85 | 115 | 170 | 230 |
| Process blower | W | 90 | 200 | 200 | 250 | 250 |
| Heater | kw | 2.7 | 4 | 5 | 6 | 8 |
| Drying temp. | °C | 150 | | | | |
| System control | | PID auto tuning microprocessor | | | | |
| System power | V | AC220~480V, 3P 50 / 60HZ | | | | |
| Control power | V | AC220V, 1P | | | | |
| Compressed air pressure | bar | 4~6 | | | | |
| PVC hose | inch | 1.5 | | | | |
| Conveying blower | kw | 0.75 (2HP above as option.) | | | | |
| Loader control | | Max. 3 sat. (Max. 2 sat. on molding machines, 1 sta. on dryer) | | | | |
| Loader type (on machine)&capacity | L | Photo sensor / 3 | | | Photo sensor / 6 | |
| Loader type (on dryer)&capacity | L | Reed Switch / 3 | | | Reed Switch / 6 | |
| Suction bBox | | Shut-off suction box and closed-loop drying air | | | | |
| Total power | kw | 3.54 | 4.95 | 5.95 | 7 | 9 |
| Dimension (mm) | W | 750 | 750 | 890 | 890 | 900 |
| | L | 800 | 800 | 985 | 985 | 1330 |
| | H | 1550 | 1760 | 1700 | 1930 | 2200 |
| Weight | kg | 175 | 190 | 240 | 270 | 330 |

FCD Series 3-IN-1 Compact Dryers



- FCD compact dryer offers more feature as standard equipment with a smaller footprint than comparable systems, giving maximum performance in minimal space.
- Standard Dew-point -40°C ; Dew point -50°C as an option model.
- Standard PID temperature control to save the energy costs.
- Use the Honeycomb rotor design without the desiccant tower switching actions to avoid the problem of the instable Dew-points.
- The Honeycomb rotor has service life at least 6 years, it can be cleaned as soon as poor drying efficiency is found.
- Automatic Dehumidifying system and Regeneration circling system.
- Closed loop circuit design eliminates the risk of moisture re-absorption and suitable for polymer drying applications involving particularly large quantities hygroscopic material.
- The Multiple safety protection device.

Specification

| Model | FCD | 530 | 550 | 575 | 10100 | 10150 | 18200 | 18300 |
|--------------------|------|---------------------------------------|------|------|-------|-------|-------|-------|
| Drying hopper | kg | 30 | 50 | 75 | 100 | 150 | 200 | 300 |
| Dewpoint | °C | -40 | | | | | | |
| Air flow | cmh | 50 | | | 100 | | 180 | |
| Drying temperature | °C | 150 (180°C High temp. type as option) | | | | | | |
| Processing blower | kw | 0.55 | | | 0.75 | | 1.5 | |
| Regen. blower | kw | 0.25 | | | 0.55 | | | |
| Processing heater | kw | 2.7 | 4 | 5 | 6 | 8 | 10 | 13 |
| Regen. heater | kw | 2.5 | | | 4 | | 5 | |
| Processing way | | Honeycomb rotor | | | | | | |
| Rotor motor | kw | 0.015 | | | | | | |
| System control | | PID auto tuning microprocessor | | | | | | |
| Processing outlet | inch | 2 | | | 2.5 | | | |
| Regen. outlet | inch | 1.5 | | | 2.5 | | | |
| Cooling water flow | gpm | 1.5 | | | 3 | | 6 | |
| Water connect | inch | 1 / 2 | | | 3 / 4 | | | |
| Power supply | V | AC220~480V, 3P 50 / 60HZ | | | | | | |
| Control volt | V | AC220V, 1P | | | | | | |
| Compressed air | bar | 4~6 | | | | | | |
| Conveying blower | kw | 0.75 (2HP above as option.) | | | | | 1.5 | |
| Total power | kw | 6.8 | 8.2 | 9.2 | 12.2 | 14.2 | 18.95 | 21.95 |
| | W | 840 | 840 | 920 | 920 | 1215 | 1560 | 1560 |
| | L | 980 | 980 | 1270 | 1270 | 890 | 917 | 917 |
| Dimension (mm) | H | 1550 | 1760 | 1700 | 1930 | 2146 | 2045 | 2300 |
| | kg | 210 | 230 | 250 | 335 | 375 | 450 | 475 |

HERE BEGINS YOUR ULTIMATE VALUE

FCD-HL Series Heatless Compact Units



- Closed-loop conveying device eliminates the possibility of moisture regain during material conveying.
- Hot air recycler equipped as standard, featuring energy saving, no exhaust of hot air and dust, and environmental protection.
- Shut-off suction box equipped as standard ensures no material remains in the material line after each loading cycle.
- Double-wall drying hopper features hot air down-blowing and cyclonic exhaust design, it maintains a steady temperature and increase drying efficiency.
- Heatless regenerative device can supply dry air with relative low dewpoint to speed up material handling process.

Specification

| Model | FCD-HL | 30 | 50 | 75 | 100 | 150 | 200 |
|---|---------|--|------|------|------------------|------|-------|
| Hopper dryer(double-wall) | litre | 50 | 85 | 115 | 170 | 230 | 335 |
| Dewpoint | °C | -40 (for HL model only) | | | | | |
| Process blower | W | 90 | 200 | 200 | 250 | 250 | 300 |
| Heater | kw | 2.7 | 4 | 5 | 6 | 8 | 10 |
| Drying temp | °C | 150 | | | | | |
| System control | | PID Auto tuning microprocessor | | | | | |
| System power | V | AC220~480V, 3P 50/60HZ | | | | | |
| Control power | V | AC220V, 1P | | | | | |
| Compressed air volume (for HL model only) | l / min | 50 | | | 100 | | |
| Compressed air pressure | bar | 4~6 | | | | | |
| PVC hose | inch | 1.5 | | | | | |
| Conveying blower | kw | 0.75 (2HP above as option.) | | | | | |
| Loader control | | Max. 3 Sat. (Max. 2 sat. on molding machines, 1 sta. on dryer) | | | | | |
| Loader type (on machine) & capacity | L | Photo sensor / 3 | | | Photo sensor / 6 | | |
| Loader type (on dryer) & capacity | L | Reed switch / 3 | | | Reed switch / 6 | | |
| Suction box | | Shut-off suction box and closed-loop drying air | | | | | |
| Total power | kw | 3.54 | 4.95 | 5.95 | 7 | 9 | 11.05 |
| Dimension (mm) | W | 840 | 840 | 920 | 920 | 1000 | 1000 |
| | L | 980 | 980 | 1270 | 1270 | 1350 | 1350 |
| | H | 1550 | 1760 | 1700 | 1930 | 2146 | 2200 |
| Weight | kg | 220 | 240 | 300 | 340 | 420 | 470 |

Products / Drying and Dehumidifying Equipment

FDD Series 2-in-1 Compact Dryers



- The FDD Compact Dryer use Honeycomb dehumidifier and Drying hopper with compact stand.
- Each model combines dehumidifying and drying functions into a single unit.
- Insulated drying hopper features dry air down-blowing and cyclone exhaust design. This improve drying efficiency and reduces energy consumption while maintain a steady drying effect.
- Compact in size for ease of movement and space saving.
- Material processing is controlled via microprocessor as standard, more convenient control and auto operation.
- Dewpoint monitor can be filled by option to check dry air dewpoint.
- Optional suction box and hopper loader for added convenience when conveying material.

Specification

| Model | FDD | 550 | 575 | 10100 | 10150 | 18200 | 18300 | 30400 | 30500 | 30600 | 40600 | 40800 | |
|--------------------|------|---------------------------------------|------|-------|-------|-------|-------|-------|-------|-------|-------|-------|--|
| Drying hopper | kg | 50 | 75 | 100 | 150 | 200 | 300 | 400 | 500 | 600 | 600 | 800 | |
| Dewpoint | °C | -40 | | | | | | | | | | | |
| Air flow | CMH | 50 | | 100 | | 180 | | 300 | | 400 | | | |
| Drying temperature | °C | 150 (180°C High temp. type as option) | | | | | | | | | | | |
| Processing blower | kw | 0.55 | | 0.75 | | 1.9 | | 3 | | 5.5 | | | |
| Regen. blower | kw | 0.25 | | 0.55 | | | | 0.75 | | | | | |
| Processing heater | kw | 4 | 5 | 6 | 8 | 10 | 13 | 20 | | 24 | | | |
| Regen. heater | kw | 2.5 | | 4 | | 5 | | 6 | | 8.5 | | | |
| Processing way | | Honeycomb rotor | | | | | | | | | | | |
| Rotor motor | kw | 0.015 | | | | 0.025 | | | | | | | |
| System control | | PID Auto tuning microprocessor | | | | | | | | | | | |
| Processing outlet | inch | 2 | | 2.5 | | 3 | | | | | | | |
| Regen. outlet | inch | 1.5 | | 2.5 | | 6 | | | | | | | |
| Cooling water flow | gpm | 1.6 | | 3 | | 6 | | 9 | | 12 | | | |
| Water connect | inch | 1/2 | | 3/4 | | | | | | | | | |
| Power supply | V | AC220~480V, 3P 50/60HZ | | | | | | | | | | | |
| Control volt. | V | AC220V, 1P | | | | | | | | | | | |
| Compressed air | bar | 4~6 | | | | | | | | | | | |
| Total power | kw | 8.2 | 9.2 | 11.8 | 13.8 | 17.6 | 20.9 | 30.2 | 30.2 | 30.2 | 35.5 | 39.5 | |
| Dimension (mm) | W | 1200 | 1200 | 1415 | 1415 | 1415 | 1415 | 1900 | 1900 | 1900 | 1900 | 1900 | |
| | L | 778 | 778 | 898 | 898 | 1005 | 1005 | 1200 | 1200 | 1307 | 1307 | 1307 | |
| | H | 1471 | 1696 | 1819 | 2144 | 2141 | 2396 | 2418 | 2768 | 2723 | 2723 | 3273 | |
| Weight | kg | 250 | 270 | 360 | 400 | 475 | 505 | 620 | 655 | 670 | 690 | 726 | |

HERE BEGINS YOUR ULTIMATE VALUE

FCAD Series Compressed Air Dryer

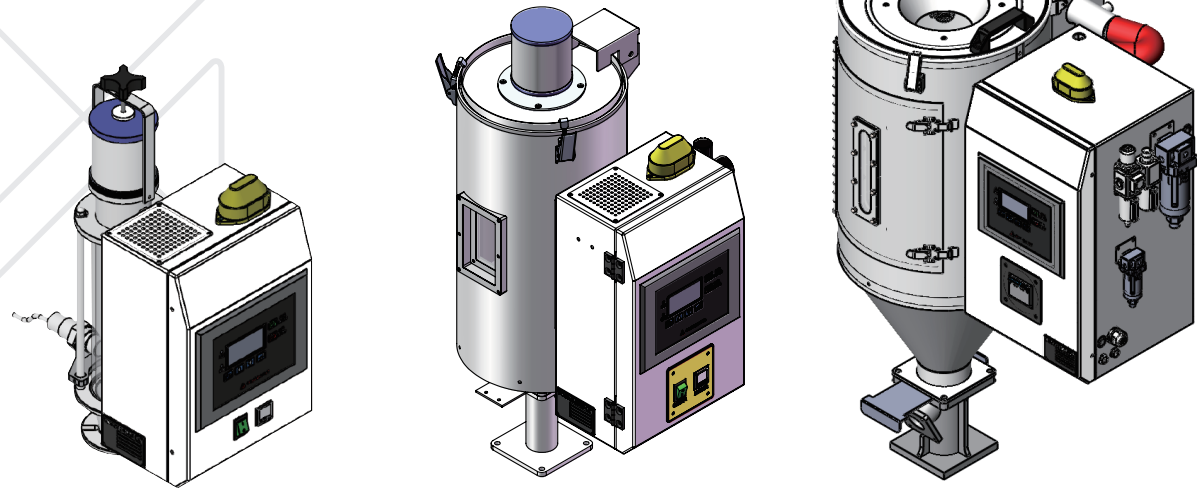

P.I.D. temperature controller can reach the accuracy of $\pm 1^{\circ}\text{C}$, Equipped with overheat protection to avoid excessively high drying temperature. Equipped with air outlet filter, which is used to filter dried air exhausted to outside. Warning light can monitor machine operation. Adopts compressed air to dry plastic materials with

good and stable drying effect, and is not influenced by ambient temperature and humidity. Function of compressed air pressure detection makes a safe and reliable operation. Voltage-output type temperature controller collocating with SSR control loop can effectively prolong the lifespan of device.

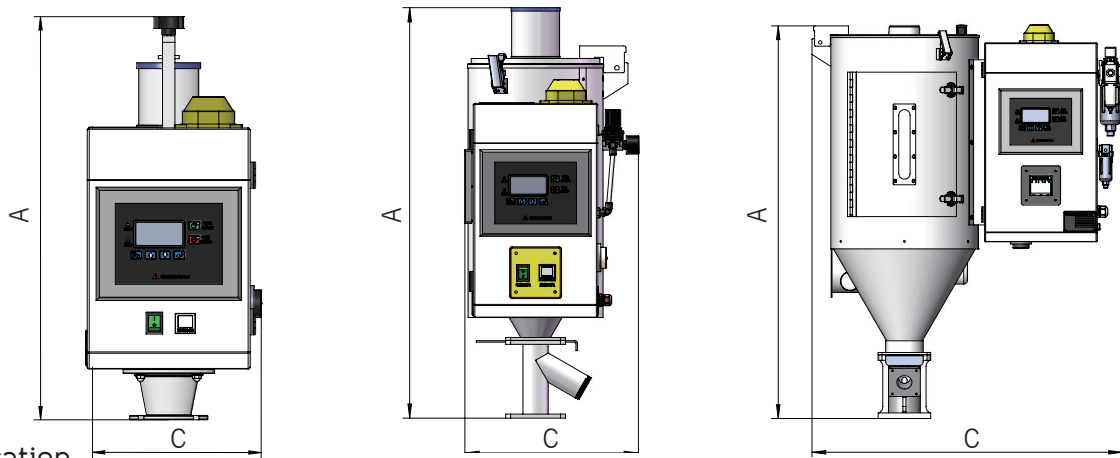

Specification

| Model | | FCAD-1 | FCAD-4 | FCAD-8 | FCAD-15HL | FCAD-30HL | FCAD-50HL | |
|------------------------|--------------------|---------------------------|--------|------------------------|-----------|-----------|-----------|--|
| Drying temperature | $^{\circ}\text{C}$ | 38-176 $^{\circ}\text{C}$ | | | | | | SPECIFICATION NOTES 5bar, clean dry compressed air pressure dewpoint of 5 $^{\circ}\text{C}$; residual oil content of less than 3mg/m 3 |
| Dewpoint | $^{\circ}\text{C}$ | -18 $^{\circ}\text{C}$ | | -40 $^{\circ}\text{C}$ | | | | |
| Airflow standard cubic | L | 1.5 | 8 | 16 | 30 | 60 | 85 | |
| Heating capacity | kw | 0.5 | | | | | 2 | |
| hopper inlet pipe size | inch | 3 / 8 | | | | | | |
| Dimension | | | | | | | | |
| Height (A) | mm | 495 | 700 | 740 | 800 | 1207 | | |
| Width (B) | mm | 345 | 555 | 615 | 710 | 710 | | |
| Length (C) | mm | 360 | 435 | 435 | 500 | 500 | | |
| Weight | kg | 12 | 20 | 25 | 30 | 35 | 35 | |
| Voltage-total amps | A | 2.3 | 4.5 | 4.5 | 4.5 | 4.5 | 4.5 | |

Formax recommends purchasing the optional membrane when: Your process requires that you obtain a dewpoint of -40 $^{\circ}\text{C}$, or the compressed air dewpoint you are supplying is above 4 $^{\circ}\text{C}$.



27

Dosing and Mixing Equipment

HERE BEGINS YOUR ULTIMATE VALUE

FVS Series Volumetric Screw Dosers



- Auto synchronization to extruder speed.
- Integrated hopper loader control
- Warning and Alarm outout
- Recipes function
- Easy cleaning and disassembly of dosing and mixing unit

The metering is a superior concept thanks to the combination of our proprietary invention the special dosing screw, the use of a stepper moter and the unquely designed electronic controls. With this winning combination, you will achieve :

- An even dosing rate as the peaks and drops associated with screw dosing units are eliminated (see graphics below)
- Accurate and stable dosing as the stepper motor guarantees a perfect constant speed.
- An incredible high capacity range of 0.05 to 180 kg/hr
- Optimum capacity control under all circumstances thanks to our advanced control algorithm.

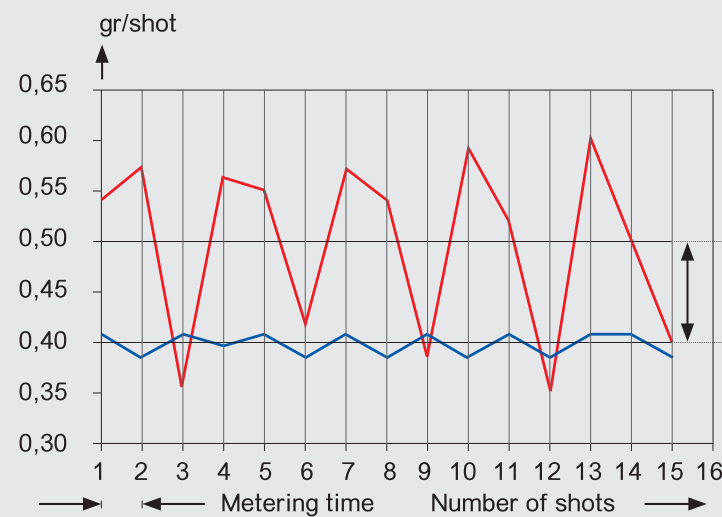

- Average of screw dosing unit
- This is your additional profit
- Average of the Formax dosing unit

FVS Series Volumetric Screw Dosers



| Technical Features | |
|--------------------|---|
| Control | Microprocessor with digital display |
| Input signal | Potential free contacts / 24 VDC contacts / Tacho input voltage |
| Motor | Accurate stepping motor (brush less) |
| Injection molding | Jog mode and continue mode |
| Extrusion | Jog and synchronic mode |
| Hopper | Stainless steel 6 liter |
| Volt / frequency | 110 / 220 Volt 50-60Hz |

| Specification | | | | | | | |
|-----------------|----------|---------|---------|---------|------|---------|-------|
| Screw / Sleeves | A3 | A10 | A15 | A20 | A30 | A20HT | A30HT |
| g / s | 0.05~0.6 | 0.2~1.8 | 0.3~4.5 | 0.4~7.5 | 1~14 | 0.4~7.5 | 1~14 |

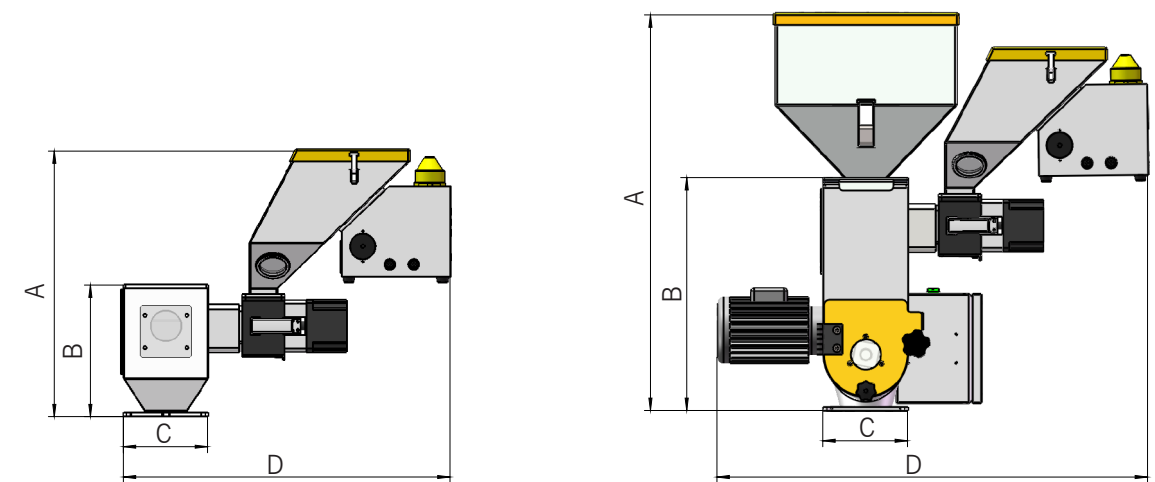

| Model | A(mm) | B(mm) | C(mm) | D(mm) | E(mm) |
|--------|-------|-------|-------|-------|-------|
| FVS | 445 | 219 | 140 | 549 | 212 |
| MIX-3 | 657 | 788 | 140 | 719 | 416 |
| MIX-15 | 385 | 513 | 260 | 772 | 443 |

HERE BEGINS YOUR ULTIMATE VALUE

FGS Series Gravimetric Screw Dosers



- Stores up to 999 recipes, shortened setup time
- Easy maintenance and cleaning when switching colors and materials
- Extreme accuracy and repeatability allows precise dosing and prevents overdosing of materials
- Loss-in-weight controlling function allows optimum adjustment of operating point
- Improved final product quality, reduced number of rejects
- Suited to any injection molding, extrusion and blow molding machines

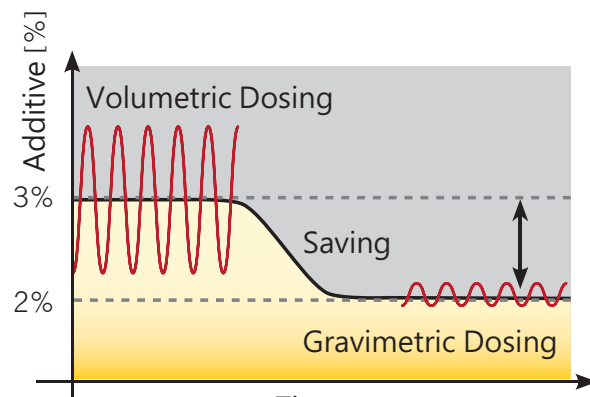
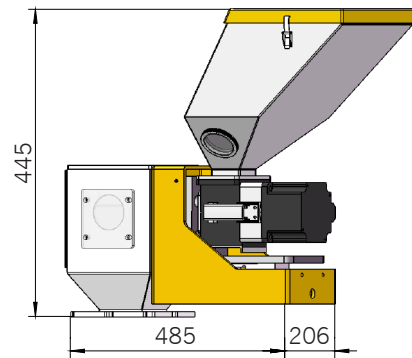

| Technical Features | |
|--------------------|---|
| Hopper | 6 / 12 Liter |
| Output range | 0.05-14 g / s |
| Motor | Accurate stepping motor (brush less) |
| Controller | Microprocess or with digital display |
| Load cell | 15 kg max. |
| Loader | Automatic integral venturil vacuum loader |
| Weight | 16kg |
| Volt / frequency | 100-240v, 200w, 50 / 60hz |

FGB Series Gravimetric Blenders



- Compact, space saving and modular design.
- Simple setting of required percentages and ratios.
- Accurate and repeatable process.
- While blending the next batch is weighted.
- Self calibration. During the dosing cycle the control automatically corrects differences from the preset values.
- Easy installation on, or next to the processing machine.
- More flexibility because of different types of control.
- Suited as central-blender for several machines.
- Hopper loaders of your own choice.
- Gravimetric / volumetric mode to increase throughput.
- Easy cleaning of weigh pan and mixing chamber.
- Security password levels.
- More languages on the display.
- Accuracy 1/1000.

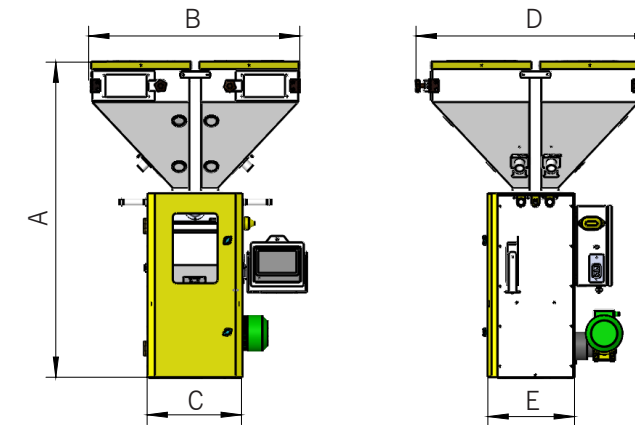

Specification

| Model | | FGB-G1 | FGB-G2 | FGB-G5 | FGB-G10 | FGB-G25 |
|----------------|----|--------|--------|--------|---------|---------|
| Dimension A | mm | 805 | 1180 | 1261 | 1674 | 2150 |
| Dimension B | mm | 697 | 843 | 972 | 1370 | 1663 |
| Dimension C | mm | 250 | 379 | 375 | 500 | 650 |
| Dimension D | mm | 644 | 892 | 892 | 1342 | 1864 |
| Dimension E | mm | 250 | 348 | 275 | 460 | 650 |
| Weight approx. | kg | 60 | 75 | 85 | 160 | 185 |

| Model | | FGB-G1 | FGB-G2 | FGB-G5 | FGB-G10 | FGB-G25 |
|---------------------|---------|--------|---------|---------|-----------|-----------|
| Number of component | | 2~4 | 2~6 | 2~6 | 2~7 | 2~10 |
| Kg/hr max. | kg / hr | 45~60 | 210~260 | 670~840 | 1100~1860 | 2060~2980 |

HERE BEGINS YOUR ULTIMATE VALUE

FGM Series / Gram Per Meter



- Pipe-/Tube Extrusion
- Cable Extrusion
- Profile Extrusion
- Film Extrusion
- Reliable realisation of product recipes
- Constant weight per metre, +/-0,5%
- Constant product quality, independent of bulk density variations
- Reduced material use due to lower set values, savings of approx. 10%
- Shortened set-up times due to precise and constant recording of production data(mass throughput, weight per metre) as well as an increased efficiency

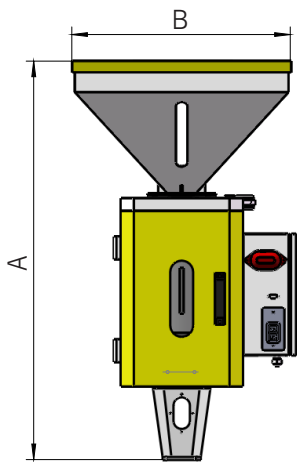

| Model | FWM350 | | FWM500 | |
|-----------------------|--|-----------------|---|------------------|
| Voltage | V | 220V | 220V | 220V |
| Output | Kg / hr | 350 kg / hr | 500 kg / hr | 500 kg / hr |
| Power | kw | 28.8 kw | 28.8 kw | 28.8 kw |
| Dimension (L x W x H) | mm | 574 x 574 x 952 | | 574 x 574 x 1165 |
| Description | Extruding metering controller | 1PS | Extruding metering controller | 1PS |
| | Fuji man-machine | 1PS | Fuji man-machine | 1PS |
| | 7 inch TF164K.800 | | 10 inch TF164K.800 | |
| | Load cell | 1PS | Load cell | 1PS |
| | Multi-functional Load-cell based Electric meter Based electric | 1PS | Multi-functional Load-cell based Electric meter | 1PS |
| | Courter encoder | 1PS | Courter encoder | 1PS |
| | Hopper | 1PS | Hopper | 1PS |

FLC Series / Gravimetric Liquid Color



MIDEXX™ Gravimetric Dosing Platform is a loss in weight system which utilizes a very accurate scale system; it requires no calibration and compensates for fluctuations in material density and wear on equipment and tubing.

Shot size and LDR are the only inputs required to start dispensing. The pump will self-calibrate continuously. MID's revolutionary design of the container holder enables fast color changes and little waste of colorant. The optional quick disconnect tubing makes the changing of the colorant easy with no mess.

Fastest and easiest color change cycle times, maximum continuous throughputs, and highest processing stability. Bundled in clean, solid, and cost-effective systems. This is how the innovative Dosing and Dispensing solutions from Micro Interface Design secure your productivity.

Precise flow rates ensuring feasibility for pumping a wide spectrum of Colorants and Additives for plastics industry that can range from small-flow Injection

applications all the way to high capacity Extrusion lines.

Global, Reliable, and dedicated to Partnership. You can always rely on Micro Interface Design

Technical Features

- Peristaltic, Progressive Cavity Drive
- Volumetric and Gravimetric modes
- Stepper Motor Drive for precise metering
- Injection and Extrusion modes
- Automatic adjustment to injection cycle recovery time variations
- Automatic or manual calibration
- Automatic storage of settings during power down
- Electrical power input of 100-220 VAC, 50/60 Hz
- Unit Weight = 10Kg
- Two year warranty
- USB connection
- Wi-Fi connectivity (optional) with remote
- Monitoring and Control software



HERE BEGINS YOUR ULTIMATE VALUE

FPV Series Proportional Valve

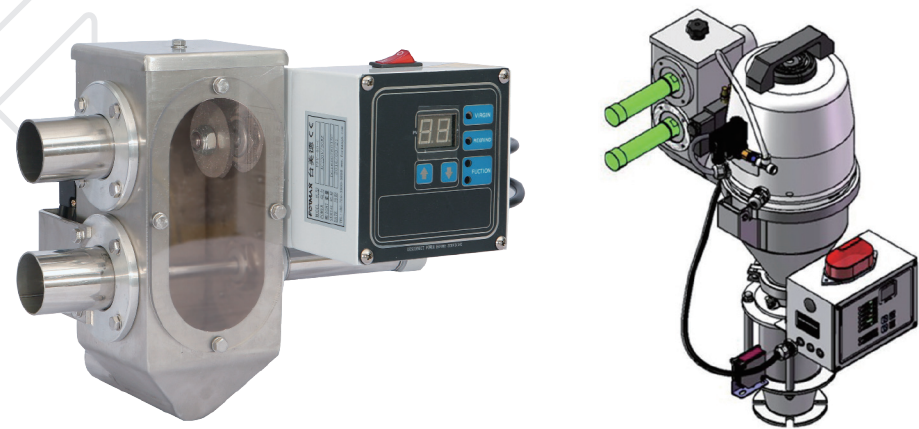

European type design, classy appearance, easy installation and operation.

- Unique design of valve body, make material conveying more smooth.
- The performance of solenoid valve is so stable that the air cylinder acts accurately to ensure a proportional mixing of new and regrind materials.

- Instant recycling of regrind materials to reduce production cost.
- Control box is optionally available when performing in other situations. Equipped with 1~4 levels working function selection, making material mixing more evenly.

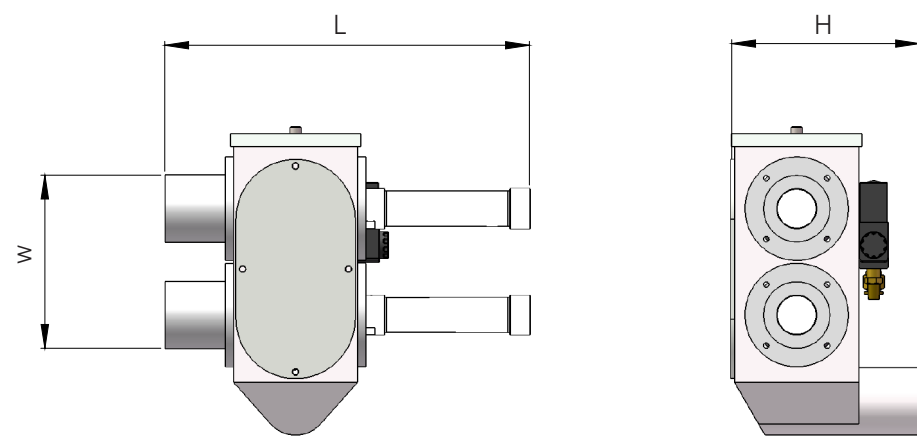

| Model | | FPV-40 | FPV-50 | FPV-65 | FPV-75 |
|-----------|--------------|-----------------|--------|-----------------|-----------------|
| Pipe size | inch | 1.5 | 2 | 2.5 | 3 |
| Voltage | v | 220 | | | |
| Capacity | kg / hr | 380 | 550 | 700 | 850 |
| Dimension | L x W x H mm | 251 x 232 x 142 | | 318 x 243 x 106 | 380 x 352 x 167 |



35

Heating and Cooling Equipment

HERE BEGINS YOUR ULTIMATE VALUE

FW Series

Water Temperature Controllers



- Self-optimizing microprocessor controller with digital display of set and actual temperature.
- The module design is compact, economical, efficient and basically maintenance free.
- Automatic water drain when change the mould as option function.
- Complete with safety protection and error indication system.
- Rapid heating and cool off speeds, temperature is kept stable at all time.
- Electrical circuit built to comply with CE safety equipment as option.
- Use German speck pump.

Specification

| Model | | FW1205S | FW1210S | FW1220S | FW1230Y | FW1250Y |
|---------------------|--|--|--|-------------|----------------------|--------------|
| Power supply | V | AC220~460, 50 / 60Hz, 3Phase | | | | |
| Temperature range | °C | 50~120 °C | | | | |
| Media | | Water | | | | |
| Heater | kw | 3 | 6 | 9 | 18 | 27 |
| Tank capacity | Ltr | W / O tank | | | | |
| Cooling way | | Direct cooling | | | | |
| Cooling capacity | kcal / hr | 7200 | 9000 | 12000 | 18000 | 24000 |
| Temperature control | °C | PID (±0.5) | | | | |
| Pump | type | Gear Pump (Mechanical Seal) | | | Vortex Pump | |
| | power (kw) | 0.5 | 0.75 | 1.5 | 2.2 | 3.7 |
| | max. pressure 50 / 60HZ(kg / cm ²) | 4 | 5.2 | 6.5 | 2.6 | 3.8 |
| | output 50 / 60HZ (ltr / min) | 27 | 45 | 80 | 315 | 367 |
| Total power | kw | 3.5 | 6.75 | 10.5 | 20.2 | 30.7 |
| Min. water pressure | kg / cm ² | 2 | | | | |
| Cooling water pipe | inch / set | 1/2" PT | | | | |
| Media pipe | inch / set | 3 / 8" PT-2in-outlet | 3 / 8" PT-4in-outlet (1HP above is optional) | | 3 / 8" PT-4in-outlet | |
| Dimension(LxWxH) | mm | 760x300x600 | | 840x300x840 | 990x300x840 | 1000x400x900 |
| Weight | kg | 45 | 50 | 55 | 75 | 110 |
| Option | | 1 · L:Lux (Auto Drain) 2 · Filter 3 · 3 / 8" PT-4in-outlet (1HP above is optional) | | | | |



- Self-optimizing microprocessor controller with digital display of set and actual temperature.
- The module design is compact, economical, efficient and basically maintenance free.
- Automatic water drain when change the mould as option function.
- Complete with safety protection and error indication system.
- Rapid heating and cool off speeds, temperature is kept stable at all time.
- Electrical circuit built to comply with CE safety equipment as option.
- Use German speck pump.

Specification

| Model | | FW1410S | FW1420S | FW1615S | FW1815S |
|---------------------|---|--|---------|----------------------------------|-----------|
| Power supply | V | AC220~460, 50 / 60Hz, 3Phase | | | |
| Temperature range | °C | 50~140 °C | | 50~160 °C | 50~180 °C |
| Media | | Water | | | |
| Heater | kw | 9 | | | |
| Tank capacity | ltr | W / O tank | | | |
| Cooling way | | Indirect cooling | | | |
| Cooling capacity | kcal / hr | 9000 | 15000 | | |
| Temperature control | °C | PID (±0.5) | | | |
| Pump | type | Gear pump (mechanical seal) | | Magnetic drive pump (sealless) | |
| | power (kw) | 0.75 | 1.5 | 1.1 | |
| | max. pressure 50 / 60HZ (Kg / cm ²) | 5.2 | 3.1 | 6 | 5.7 |
| | max. output 50 / 60HZ (ltr / min) | 45 | 80 | 60 | |
| Total power | kw | 6.8 | 10.55 | | 10.15 |
| Media pipe | kg / cm ² | 3 / 8" PT- 4 inlet / outlet | | | |
| Dimension (LxWxH) | mm | 840 x 300 x 840 | | | |
| Weight | kg | 75 | 80 | | |
| Option | | 1 · L:Lux (Auto Drain) 2 · Filter 3 · 3 / 8" PT-4in-outlet (1HP above is optional) | | | |

FO Series Oil Temperature Controllers



- Self-optimizing microprocessor controller with digital display of set and actual temperature.
- The module design is compact, economical, efficient and basically maintenance free.
- Automatic oil drain when change the mould as option function.
- Complete with safety protection and error indication system.
- Rapid heating and cool off speeds, temperature is kept stable at all time.
- Electrical circuit built to comply with CE safety equipment as option.
- Use German speck pump

Specification

| Model | | FO1805S | FO1810S | FO1820S | FO1830Y | FO1850Y | FO2005S | FO2015S |
|---------------------|---|---|-----------------------|---------|-----------------------|-----------------------|--------------------------------|-----------------------|
| Power supply | V | AC220~460, 50 / 60Hz, 3Phase | | | | | | |
| Temperature range | °C | 50~180°C | | | 50~180°C | | 50~200°C | |
| Media | | Thermal oil | | | | | | |
| Heater | kw | 6 | 9 | 9 | 24 | 36 | 6 | 9 |
| Tank capacity | ltr | 8 | | | 10 | 12 | 8 | |
| Cooling way | | Indirect cooling | | | | | | |
| Cooling capacity | kcal / hr | 7200 | 9000 | 12000 | 25000 | 35000 | 9000 | 12000 |
| Temperature control | °C | PID (±0.5) | | | | | | |
| Pump | type | Gear pump (mechanical seal) | | | Vortex pum | | Magnetic drive pump (sealless) | |
| | power (kw) | 0.5 | 0.75 | 1.5 | 2.2 | 3.7 | 0.5 | 1.1 |
| | max. pressure 50 / 60HZ (kg / cm ²) | 4 | 5.2 | 6.5 | 2.6 | 3.8 | 5 | 6 |
| | max. output 50 / 60HZ (ltr / min) | 27 | 45 | 80 | 315 | 367 | 40 | 60 |
| Total power | kw | 6.5 | 9.75 | 10.5 | 26.2 | 39.7 | 6.5 | 10.1 |
| Min. water pressure | kg / cm ² | 2 | | | | | | |
| Cooling water pipe | inch / set | 1 / 2" PT | | | | | | |
| Media pipe | inch / set | 3 / 8" PT-2 in-outlet | 3 / 8" PT-4 in-outlet | | 3 / 8" PT-4 in-outlet | 3 / 8" PT-2 in-outlet | | 3 / 8" PT-4 in-outlet |
| Dimension (LxWxH) | mm | 760x300x600 | 840x300x840 | | 990x300x840 | 1000x400x900 | 840x300x840 | |
| Weight | kg | 50 | 55 | 65 | 80 | 115 | 60 | 65 |
| Option | | 1 · L:Lux (Auto Drain) 2 · 3 / 8" PT-4in-outlet (1HP above is optional) | | | | | | |

FCV Series Water or Oil Temperature Controllers



- FCV is designed with operation in pressure or suction mode, to allow continuous production despite leakage from mould or connections.
- Automatic mould drainage ; drain the remains of medium when change the mould.
- Automation water refill (except oil operation), and remove the air in the pipes.
- Self-optimizing microprocessor controller with digital display of set and actual temperature.
- Electric control panel and machine are separated to obtain good effective isolation, and able to extend the service life of the electric parts.
- Rapid heating and cool off speeds, temperature is kept stable at all time.
- Complete with safety protection and error indication systems.
- Electrical circuit built to comply with CE safety equipment as option.
- Use German speck pump

Specification

| Model | | FCV05 | FCV10 |
|---------------------|---|---|-----------------------|
| Power supply | V | AC220~460, 50 / 60Hz, 3Phase | |
| Temperature range | °C | Water50~90 °C , Oil 150 °C | |
| Media | | Water ; Oil | |
| Heater | kw | 6 | 9 |
| Tank capacity | Ltr | 15 | |
| Cooling way | | Indirect cooling | |
| Cooling capacity | kcal / hr | 9000 | |
| Temperature control | °C | PID (±0.5) | |
| Pump | type | Delivery pump (sealless) | |
| | power (kw) | 0.5 | 1.1 |
| | max. pressure 50 / 60HZ (kg/cm ²) | 3.5 | 6 |
| | max. output 50 / 60HZ (ltr / min) | 60 | 70 |
| Total power | kw | 9.5 | 10.1 |
| Min. water pressure | kg / cm ² | 2 | |
| Cooling water pipe | inch / set | 1 / 2" PT | 1 / 2" PT |
| Media pipe | inch / set | 3 / 8" PT-4 in-outlet | 3 / 8" PT-4 in-outlet |
| Dimension (LxWxH) | mm | 760 x 300 x 600 | 760 x 300 x 600 |
| Weight | kg | 45 | 45 |
| Option | | FCV vacuum funtion and auto refill (water type) | |

HERE BEGINS YOUR ULTIMATE VALUE

FOH Series / H.T. Oil Temperature Controllers



- High temperature controller to control die casting, molding, extruding equipment, roller and hi-tech precise industrial equipment up to 320°C by using oil.
- Safe structure and guaranteed durability adapting ultra-high temperature, large amount of oil, heat-resistant pump.
- Leaking phenomenon removed by equipping magnet pump for high temperature, zero moisture contents within the closed circuit.
- PID temperature control for heating and cooling , cost save for sub-tangential force.
- Protection device against high temperature with special circuit structure, overheating and abnormalities error indicators.
- All pumps are manufactured from absolute precision and excellent anti-erosive. It ensures the high pressure and reducing and saving power consumption.
- Use German speck pump

Specification

| Model | | FOH2505Y | FOH2515Y | FOH3215S | FOH3240S |
|---------------------|---|--|-------------------|------------------|-------------------|
| Power supply | V | AC220 ~ 460, 50 / 60Hz, 3Phase | | | |
| Temperature range | °C | 100~320°C | | | |
| Media | | Oil (Monsanto : T66) | | | |
| Heater | kw | 9 | | | 24 |
| Tank capacity | ltr | 8 | | | 25 |
| Cooling capacity | kcal / hr | 8600 | | | 17200 |
| | type | Gear type (direct) | | | |
| | power (kw) | 0.5 | 1.1 | 1.1 | 2.8 |
| | max. pressure 50 / 60HZ (kg / cm ²) | 4 | 5.4 | 5.7 | 5.2 |
| Pump | max. output 50 / 60HZ (ltr / min) | 27 | 53 | 60 | 80 |
| | Total power | kw | 13.1 | | 26.8 |
| Min. water pressure | kg / cm ² | 2 | | | |
| Cooling water pipe | inch / set | 1 / 2"PT | | | |
| Media pipe | inch / set | 1 / 2"PT | 3 / 4"PT | | 1"PT |
| Dimension (LxWxH) | mm | 840 x 300 x 840 | 1000 x 700 x 1000 | 950 x 400 x 1000 | 1100 x 800 x 1200 |
| Weight | kg | 130 | 260 | 170 | 340 |
| Option | | 1. L : Lux (Auto drain) 2. In-outlet valve | | | |

FWC Series / Water-cooled Chillers



- Digital setting and display of chilled water temperature via a P.I.D controller with high and low alarm.
- Superior shell-shape condenser.
- Stainless steel chilling unit incorporates high grade seamless bronze tubing eliminates rust or corrosion.
- FAC series use Maneurop/Performer same grade high efficient fully enclosure compressor.
- Protection switch for high and low pressure, overload protection, overheat safety thermostat, anti-freezing switch and delay protection

Specification

| Model | FWC | 3 | 5 | 8 | 10 | 15 | 20 | 25 | 30 | 40 | 50 | |
|-------------------------------|---------------------|---------------------------------------|--------------|---------------|---------------|---------------|--------------------------------|-----------------------------|---------|---------|---------|--------|
| Cold water temperature | °C | 3~30 (Normal temperature) | | | | | | | | | | |
| Cooling capacity (under 50Hz) | kw | 9.27 | 15.82 | 23.4 | 30.4 | 46.8 | 60.8 | 68.68 | 9 | 123 | 156 | |
| | btu / hr | 31636 | 53989 | 79857 | 103746 | 159714 | 207492 | 234384 | 310556 | 41976 | 532381 | |
| | kcal / hr | 7972 | 13605 | 20124 | 26144 | 40248 | 52288 | 59065 | 78260 | 105780 | 134160 | |
| Compressor | type | Piston or scroll type fully enclosure | | | | | | Scroll type fully enclosure | | | | |
| | power | kw | 3.37 | 5.66 | 7.98 | 10.66 | 7.98x2 | 10.66x2 | 11.95x2 | 13.62x2 | 18.78x2 | 23.6x2 |
| | hp | 3 | 5 | 8 | 10 | 16 | 20 | 24 | 30 | 40 | 50 | |
| Refrigerant | control way | Thermo expansion valve | | | | | | | | | | |
| | type | R22 (CE Type W/ R407) | | | | | | | | | | |
| Condenser | type | Shell-shape (single circuit) | | | | | Shell-shape (multiple circuit) | | | | | |
| | inlet / outlet | inch | 1 | | 1.5 | | 2 | 2.5 | 3 | 4 | | |
| | max. flow rate | lpm | 35 | 60 | 100 | 120 | 180 | 230 | 260 | 350 | 480 | 600 |
| Evaporator | type | Shell-shape (single circuit) | | | | | Shell-shape (multiple circuit) | | | | | |
| | water tank capacity | | 60 | 150 | 200 | 330 | 350 | 450 | *** | *** | | |
| Pump | power(50Hz) | kw | 0.75 | | 1.5 | | 2.2 | | 3.7 | | 5.5 | |
| | max. output | lpm | 100 | | 200 | | 230 | | 500 | | 550 | |
| | max. pressure | bar | 1.5 | | | | 2 | | | | 2.5 | |
| Water in / outlet | inch | 1 | | 1.5 | | 2 | | 2.5 | | 3 | | |
| Total power consumption | kw | 4.12 | 6.41 | 9.48 | 12.16 | 18.16 | 23.52 | 27.6 | 30.94 | 43.06 | 52.7 | |
| Voltage (Phase) | V | 3P, 220~460V, 50/60HZ | | | | | | | | | | |
| Dimensions | (LxWxH) | mm | 900x680x1200 | 1400x840x1200 | 1660x770x1400 | 1650x710x1880 | 1880x810x1880 | 1880x910x1950 | | | | |
| Weight | kg | 130 | 150 | 300 | 430 | 735 | 820 | 900 | 1150 | 1200 | 1380 | |

HERE BEGINS YOUR ULTIMATE VALUE

FAC Series Air-cooled Chillers



- Digital setting and display of chilled water temperature via a P.I.D controller with high and low alarm.
- Superior shell-shape condenser.
- Stainless steel chilling unit incorporates high grade seamless bronze tubing eliminates rust or corrosion.
- FAC series use Maneurop/Performer same grade high efficient fully enclosure compressor.
- Protection switch for high and low pressure, overload protection, overheat safety thermostat, anti-freezing switch and delay protection

Specification

| Model | FAC | 3 | 5 | 8 | 10 | 15 | 20 | 25 | 30 | |
|-------------------------------|---------------------|---|------------------|-------------------|--------------------|--------------------------------|----------------|---------|---------|---------|
| Cold water temperature | °C | 3~30 (Normal temperature) | | | | | | | | |
| Cooling capacity (under 50Hz) | kw | 9.27 | 15.82 | 23.4 | 30.4 | 46.8 | 60.8 | 68.68 | 91 | |
| | btu / hr | 31636 | 53989 | 79857 | 103746 | 159714 | 207492 | 234384 | 310556 | |
| | kcal / hr | 7972 | 13605 | 20124 | 26144 | 40248 | 52288 | 59065 | 78260 | |
| Compressor | power (kw) | kw | 3.37 | 5.66 | 7.98 | 10.66 | 7.98x2 | 10.66x2 | 11.95x2 | 13.62x2 |
| | | hp | 3 | 5 | 8 | 10 | 16 | 20 | 24 | 30 |
| Refrigerant | control way | Thermo expansion valve | | | | | | | | |
| | type | R22 (CE type W / R407) | | | | | | | | |
| Condenser | type | High efficiency purple copper string with aluminium wings + low noise shaft fan | | | | | | | | |
| | cooled air flow | cmh | 3000 | 5000 | 8000 | 10000 | 15000 | 20000 | 25000 | 30000 |
| Evaporator | type | Shell-shape (single circuit) | | | | Shell-shape (multiple circuit) | | | | |
| | water tank capacity | L | 50 | 60 | 150 | 200 | 330 | 350 | 450 | |
| Pump | power(50Hz) | kw | 0.75 | | 1.5 | | 2.2 | | 3.7 | |
| | max. output | lpm | 100 | | 200 | | 230 | | 500 | |
| | max. pressure | bar | 1.5 | | | 2 | | | 2.5 | |
| Water in / outlet | Inch | 1 | | 1.5 | | 2 | | | 2.5 | |
| Total power consumption | kw | 4.12 | 6.41 | 9.48 | 12.16 | 18.16 | 23.52 | 27.6 | 30.94 | |
| Voltage (Phase) | V | 3P, 380~415V, 50 / 60HZ | | | | | | | | |
| Dimensions | (LxWxH) | mm | 900 x 880 x 1580 | 1770 x 850 x 1400 | 2050 x 1050 x 1500 | 2000x1130x1914 | 2200x1130x2026 | | | |
| Weight | kg | 135 | 175 | 310 | 450 | 750 | 835 | 920 | 1080 | |



43

Granulator and Recycling Equipment

HERE BEGINS YOUR ULTIMATE VALUE

FS Series

Screenless Crusher

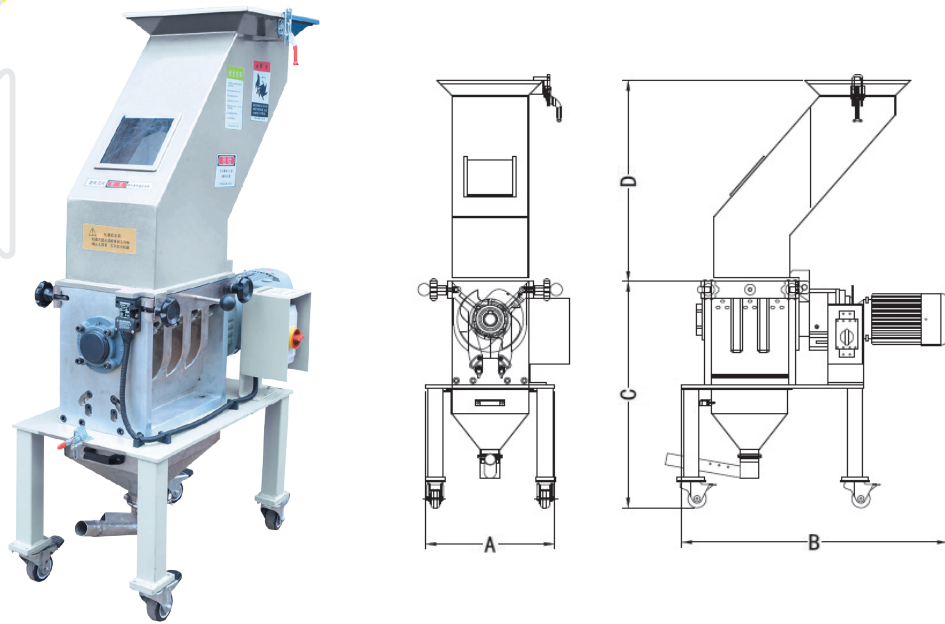

· Unique design of the tool cutting only can reduce dust bad and not easily broken ·

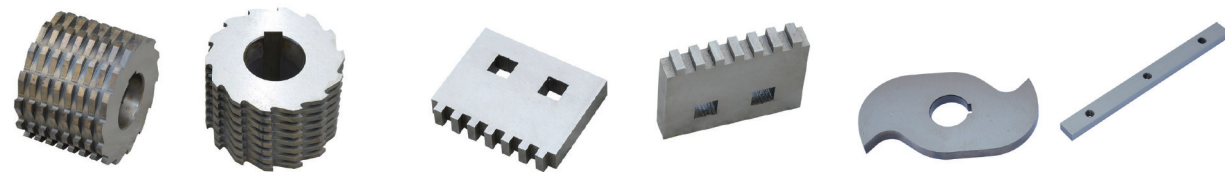

- The unique design of the full-open fuselage disassembly is simple and fast.
- Fuselage surface after electroless nickel plating surface treatment, not only to increase the hardness of the cutting room, and play a rust effect.
- Feed hopper with double stainless steel production, and more to reduce the noise.
- Thi unique design of the cutting room full open, cutting room is not dead, clean-up, easier to maintain.



Drive part : This series of models using the R series helical gear transmission, increases torque.



The motor starter electrical parts used in Eaton's Admiralty Muller switch, better protect the motor.

Specification

| Model | | FS250 | FS340 |
|-------------------|-----|---------------|---------------|
| Drive power | kw | 1.1 | 1.5 |
| Chopped mouth | mm | 252x252 | 252x341 |
| Speed | rpm | 32 | 32 |
| Claw knife number | | 2 | 3 |
| Cutter number | | 3 | 4 |
| Body size (LxWxH) | mm | 1000x460x1360 | 1100x460x1360 |
| Grinding capacity | kg | ≥ 10°C | ≥ 20 |
| Weight | kg | 180 | 220 |
| Grinding noise | db | 60~73 | 60~75 |

| | FS250 | FS340 |
|---|-------|-------|
| A | 425 | 513 |
| B | 890 | 940 |
| C | 746 | 796 |
| D | 662 | 712 |

FG180 Series

Low speed Grusher

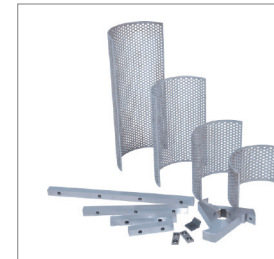

Rotor with a specially designed tool, the unique shape of the rotor knives ensure its remains fixed after regrinding cutting curve and cutting interval, do not need to adjust the tool through a complicated process, thereby reducing the disassembly tool downtime.



Rotor supported on two bearings, while the width of the rotor shaft according to the largest design, making it possible to shred massive objects. In addition, the ladder-shaped rotor blade design allows only one at any time during the cutting tool, thereby increasing the cutting torque.

FORMAX production FG low-speed crusher series, models from the FG 180/120 to FG 180/430, specially designed for crushing of recycled plastic waste generated in the molding process and the gate. FORMAX production of low-speed crusher set the general common advantages such as low noise, less dust outside, still in its design, improved

performance, such as special waste and for the broken gate and design tool, the rotor and efficient way to disassemble, reflecting the low-speed crusher FORMAX humanity. Machine used gear transmission mode, an increase of torque, the machine can start at any time, even if broken material left in the crushing chamber, you can easily start the machine.

Specification

| Model | | FG-1812 | FG-1818 | FG-1830 | FG-1843 |
|-----------------|---------|-------------|-------------|-------------|-------------|
| Speed | rpm | 150 | 150 | 150 | 150 |
| Rotating blades | | 12 | 18 | 30 | 45 |
| Fixed blades | | 2 (4 blade) | 2 (4 blade) | 2 (4 blade) | 2 (4 blade) |
| Rotor diameter | mm | 180 | 180 | 180 | 180 |
| Rotor width | mm | 120 | 180 | 300 | 430 |
| Feeding size | mm | 350 x 350 | 350 x 350 | 350 x 350 | 430 x 350 |
| Cutting chamber | mm x mm | 270 x 120 | 270 x 180 | 270 x 300 | 270 x 430 |
| Motor output | kw | 2.2 | 3.0 | 4.0 | 4.0 |
| Weight | kg | 120 | 130 | 150 | 170 |
| Dimension | | | | | |
| W (A) | mm | 420 | 420 | 420 | 420 |
| L (B) | mm | 850 | 910 | 1030 | 1240 |
| H (C) | mm | 450 | 450 | 450 | 550 |
| H (D) | mm | 600 | 600 | 600 | 900 |

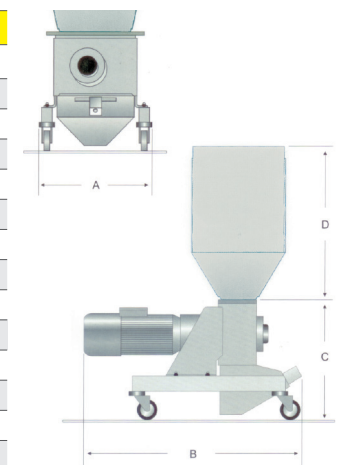

FG300 Series Medium Sized Crushers

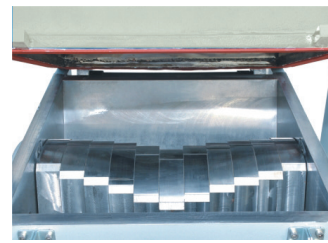
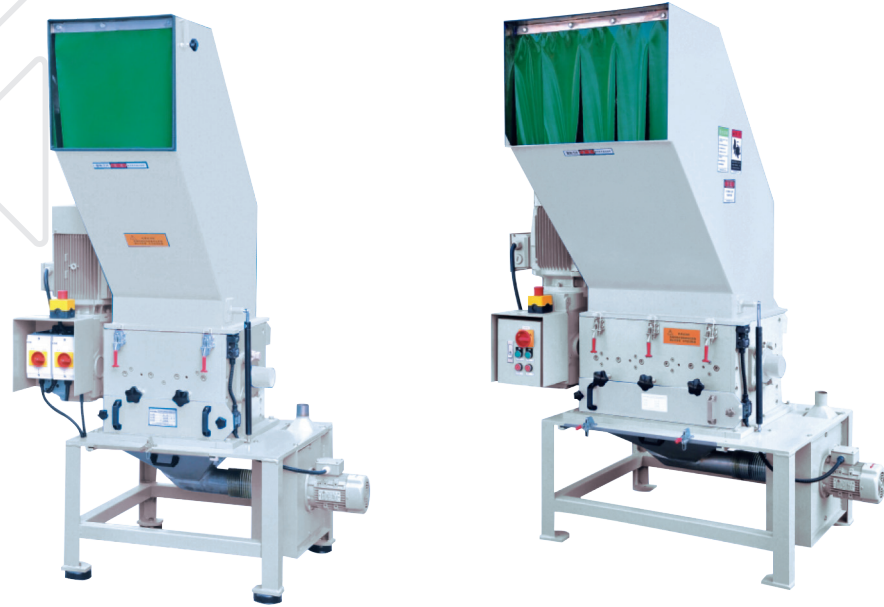

Ladder-shaped rotor arranged in V-shaped, so that it can be caught in the shredding room central broken material, this feature prevents the material posted on the wall in shredding room, while greatly increasing the shredding chamber wall in processing of glass fiber reinforced plastic products and when the wear resistance.

FORMAX production of medium-sized crushers FG 300/400 and FG 300/600 series, except with the FG 180 series crusher of advantages, more suitable for plastic bottles and other blow molded products such as insulating materials, crushing, and its unique design of the ladder-shaped transfer arranged in V-shaped knife, to seize the central cavity in the broken broken materials needed to prevent the

material attached to the sidewall of the crushing chamber, ladder-shaped rotor design allows the machine broken material at any time only one tool in the be cut, thereby increasing the machine's cutting torque. In addition, FG 300 crusher with its use can also be optional according to FG 180 ways to use the series, making more extensive use of the machine.

Specification

| Model | | FG-3040 | FG-3060 |
|-----------------|---------|-------------|-------------|
| Speed | rpm | 150 | 150 |
| Rotating blades | | 33 | 48 |
| Fixed blades | | 2 (4 blade) | 4 (4 blade) |
| Rotor diameter | mm | 300 | 300 |
| Rotor width | mm | 400 | 600 |
| Feeding size | mm | 400 x 400 | 600 x 400 |
| Cutting chamber | mm x mm | 400 x 400 | 600 x 400 |
| Motor output | kw | 7.5 | 11 |
| Weight | kg | 550 | 809 |
| Dimension | | | |
| W (A) | mm | 820 | 1100 |
| L (B) | mm | 1050 | 1010 |
| H (C) | mm | 710 | 710 |
| H (D) | mm | 1050 | 1050 |

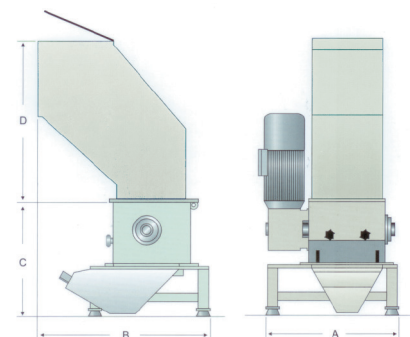

FC300 Series Sound Proof Crushers

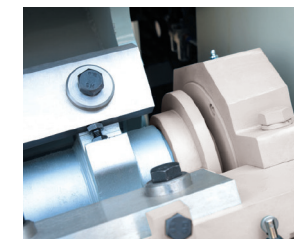

FC series models economic, reliable, easy to clean and long service life.

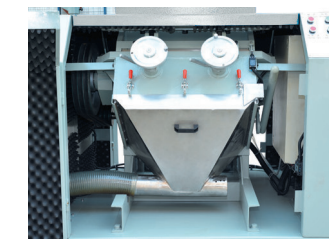

With the crushing chamber of the "V" -shaped rotor designed to ensure safe and reliable operation, and is suitable for a variety of a variety of crushed material, and even larger material is no exception.

- Built-in enclosures: to ensure that the use noise reduction, and a unique tool designed to make it easier tool change.
- Simple tool to install: the adjustments using a tool to adjust the frame, the entire tool change process in the crusher, fixed knife and rotary cutter with high tensile strength steel, regrinding many times.
- The unique cutting mode: the tool of the rotor using the latest "V" shaped cutting technique, compared with the conventional tool, "V"-shaped design materials toward the center of the rotor

- while continuing cutting, "V"-shaped structure be able to reduce the wear of the tool and crushing chamber.
- The removable Compact design: built-in enclosures designed so that the entire model is very compact, you can move the entire machine can lift or move the forklift or other lifting equipment standards.
- Efficient feeding mode: Due to the unique rotor design, even if it is a continuous feeding, crushing chamber will not be clogged.

Specification

| Model | Rotor Diameter(mm) | Width(mm) | Size(mm) | Drive Power(kw) | Width(A)(mm) | Length(B)(mm) | Height(C)(mm) |
|---------|--------------------|-----------|-----------|-----------------|--------------|---------------|---------------|
| FC-3030 | Ø300 | 300 x 300 | 400 x 290 | 7.5 | 1300 | 1500 | 1900 |
| FC-3060 | Ø300 | 300 x 600 | 400 x 590 | 15 | 1700 | 1500 | 2050 |
| FC-3080 | Ø300 | 300 x 800 | 400 x 790 | 22 | 1900 | 1500 | 2050 |

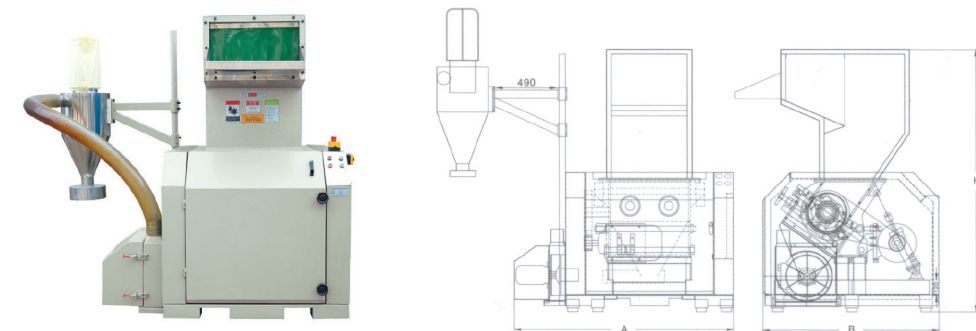

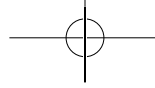

HERE BEGINS YOUR ULTIMATE VALUE

Note

