

FORMAX®

HERE BEGINS YOUR ULTIMATE VALUE

FAL Series
Three-phase Single
Hopper Loader

FAL-2P



Please read the brochure carefully before operation.

■ Coding Principle

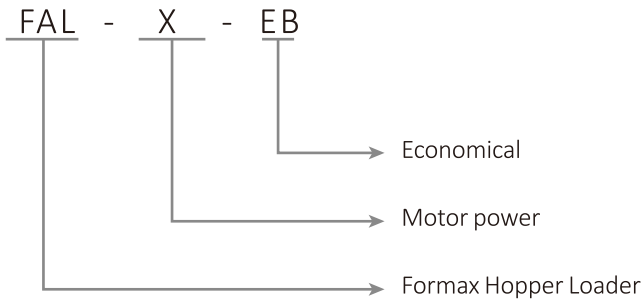

FAL-2PE

■ Features

- Motor overheat protector that can increase the service life.
- Shortage alarm informs the customer to troubleshoot.
- FAL-1P~5P can control the proportional valve FPV and Shut-off suction box independently.
- The filter barrel adopts PC (polycarbonate) that is easy to check the dust in the barrel for cleaning.
- The loader equips with RS485 interface for information exchange, which is controlled by central integrator.
- FAL-1P~5P-D has two-stage conveying function.

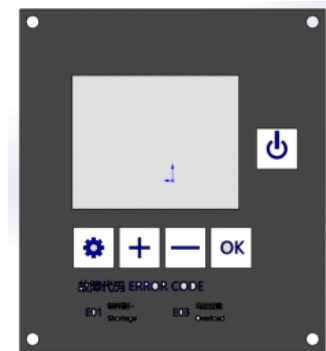

Controller

■ Application

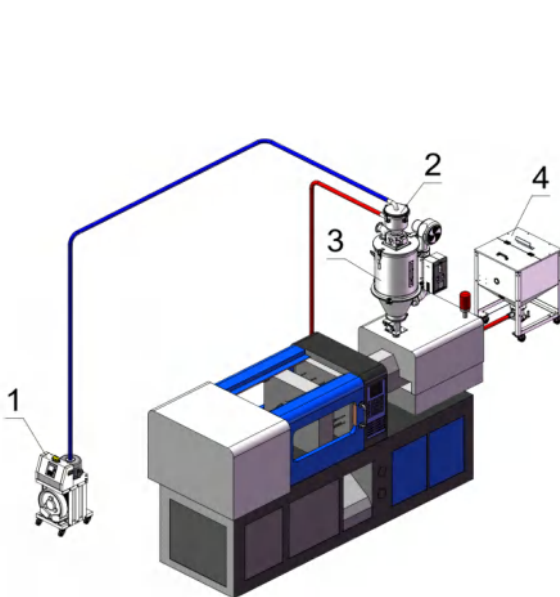

FAL-2P application

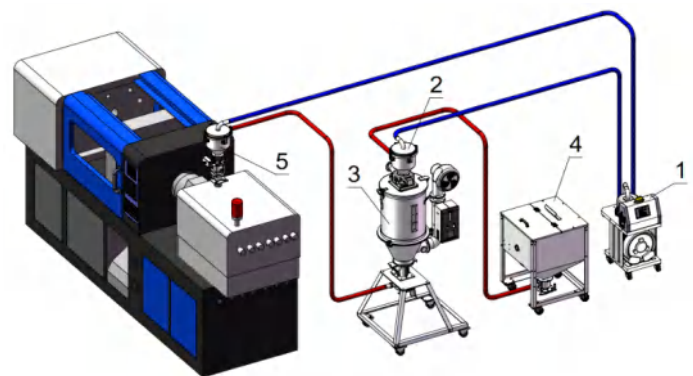

FAL-2P-D application (two-stage conveying)

- ① Main (Vacuum) unit
- ② hopper dryer
- ③ Vacuum hopper loader
- ④ Material storage tank
- ⑤ Photosensor hopper loader

Option

The airflow with dust is rotating in high speed in the cyclone dust collector, under the function of centrifugal force, the dust is gathered upon the inner wall of the cyclone dust collector, and then upon the function of gravity, the dust finally falls down and comes out through the discharging hole. Rotated airflow is shrinkage to centre of hopper and then becoming secondary vortex flows out. It's effective to filter dust from hopper dryer and avoid of air pollution. The effect is up to 80%.

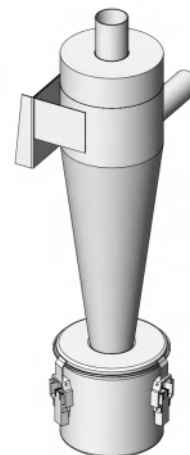

Cyclone Dust Collector

Conveying Capacity

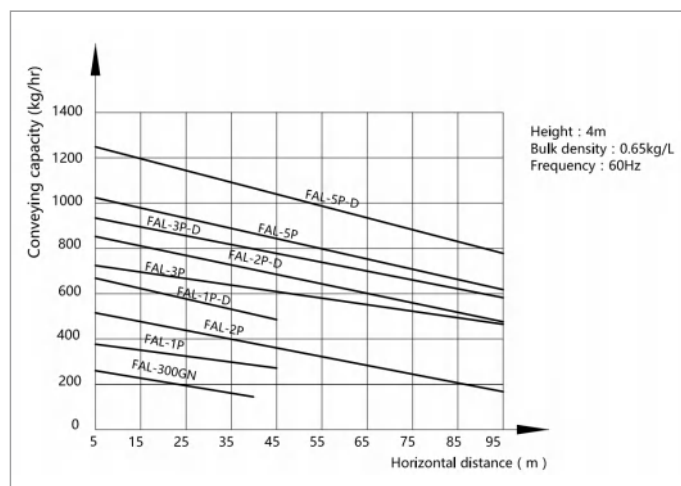
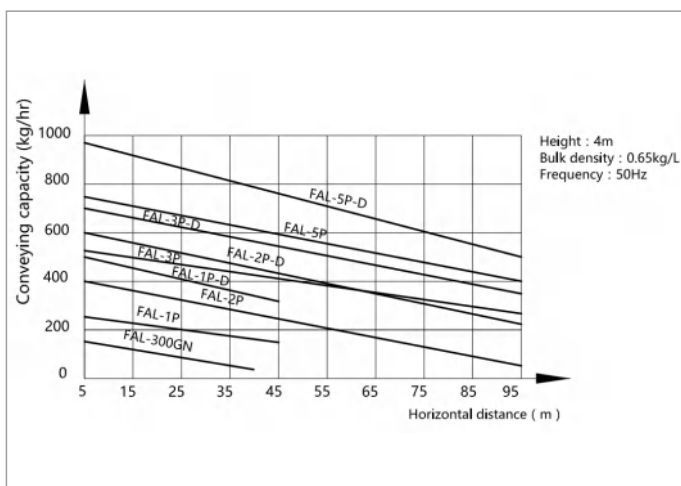

Outline Drawings



FAL-300GN (Main Unit)

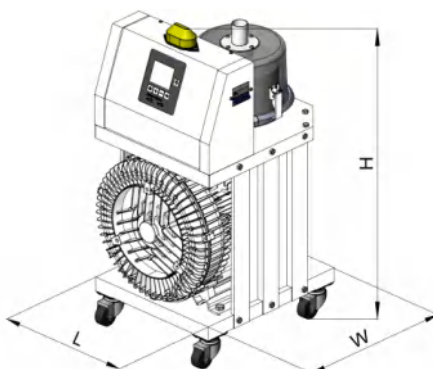

FAL-1~5P (Main Unit)

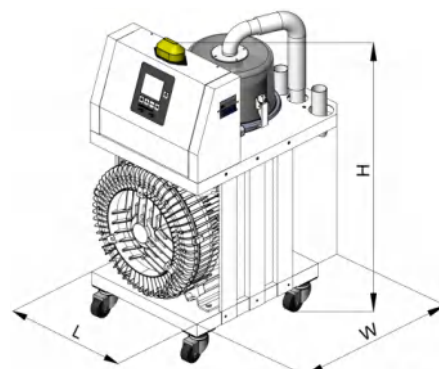

FAL-1~5P-D (Main Unit)

■ Specifications

Model	FAL-	300GN	1P	2P	3P	5P	1P-D	2P-D	3P-D	5P-D
Motor Power	kW	1.1	1.1	1.5	2.2	3.75	1.1	1.5	2.2	3.75
Material Pipe	inch	1.5	1.5	1.5	2	2	1.5	1.5	2	2
Vacuum Pipe	inch	1.5	1.5	1.5	2	2	1.5	1.5	2	2
Motor Type		Carbon brush	Inductive							
Conveying Capacity (50/60Hz)	Kg/hr	140/250	250/390	400/500	500/700	750/1050	450/650	600/850	700/950	950/1250
Hopper Capacity	L	6	6	12	12	24	6*2	12*2	12*2	24*2
Voltage	V	3Ø, 380VAC 50Hz								
Accessory	Filter dust collector	Standard								
	Cyclone dust collector	Option								
	Vacuum valve breaking	N/A								

Dimension

L	MM	300	368	368	368	440	392	392	392	440
W		360	425	425	425	465	525	525	525	550
H		565	810	810	810	850	815	815	815	873
Weight	Kg	18	28	38	43	60	30	40	45	62

Notes: 1) Test condition of conveying capacity: Plastic material of bulk density 0.65kg/L, and diameter of 3~5mm, with vertical height of 4m and the horizontal conveying distance of 5 m.
2) Power supply: 3Ø, 380VAC, 50/60Hz.

Product specifications are subject to change without prior notice.

FORMAX®

China
Formax Plastics Automation, Inc.

Dongguan
No. 9, Taida Road, Chang'an Town, Dongguan City,
Guangdong Province, China
Tel. +86-769-3899-9898 Fax. +86-769-8533-3467

Kushan
No.138-20, Hengshan Road, Kunshan, Jiangsu, China
Tel. +86-512-5700-8308 Fax. +86-512-5700-8306

Taiwan
Formax Equipment Inc.

No.12, Ln.12, Anzhong st., Luzhu Dist.,
Taoyuan City, Taiwan
Tel. +886-3-2121-725 Fax. +886-3-2127-960

www.formaxpa.com
www.formax88.com



2022-12 All rights reserved.